

CNC Vertical Lathe VNL Series



* The content of the catalogue is subject to change without notice.

NEWAY CNC EQUIPMENT(SUZHOU) CO.,LTD

No 69 Xunyangjiang Road, Suzhou New District, P.R.China
Tel: 86-512-6239 2186
Fax: 86-512-6607 1116
E-mail: cncsale@neway.com.cn
www.newaycnc.com

NEWAY CNC (USA),INC.

9757 Stafford Centre Drive Strafford,Texas 77477 USA
Tel: +1 281-969-5800
Fax: +1 281-969-5903
www.newaycnc.us



YouTube



Facebook



LinkedIn



Neway CNC Vertical Lathe

Neway's diverse vertical CNC lathe series is designed to meet the high class machining needs of the unique and different industries. The high quality and high precision guaranteed by our zero-defect manufacturing processes have won the trust and praise from many customers of worldwide.

■ Excellent Precision Stability

The basic components are made of high-strength cast iron, and the secondary aging treatment makes the machine have excellent precision stability.

■ Optimized Structural Design

The finite element analysis of the basic components enables the machine to have excellent performance in both dynamic and static conditions.

■ Reasonable Structural Layout

Compact structure and reasonable layout, effectively saving customer space.

■ High-quality Key Components

The key components are internationally well-known brands, which greatly improve the reliability of machine tools.

■ Complete Product Configurations

The product specifications are complete, to meet the machining needs of different industries, suitable for various materials' machining, such as cast iron and steel.

CONTENTS

01-20 CNC Vertical Lathe

01-08 VNL40/60/80/100

09-17 VNL125/160

18-28 VNL250/400/500

29-36 CNC Vertical Turning Center

37 Industrial Applications

38 Manufacturing and Detection

39 Control System

40 Options

VNL Series- CNC Vertical Lathe

- This series adopts integral box-type base. The rib-shaped layout is optimized by finite element analysis, which makes the machine tool have better rigidity. It adopts high-density cast iron to realize high strength and high vibration absorption;
- The spindle bearing adopts imported high-precision double-row short cylindrical roller bearing and two-way thrust angular contact ball bearing to meet the bearing requirements of axial and radial cutting forces;
- X/Z axis screw is pre-stretched structure, which can reduce the influence of temperature rise on the precision of the lead screw during machine operation;
- The vertical structure avoids the roundness deviation caused by the gravity of the workpiece during horizontal clamping, ensuring the roundness accuracy of the parts;
- The weight of the workpiece ensures that the workpiece and the fixture are closely attached, which enables the workpiece to obtain higher positioning accuracy and machining accuracy;
- A variety of chucks can be selected, and non-standard fixtures can be customized according to customers' needs;
- Applicable to high-speed steel and carbide tools. It can be used for roughing and finishing of ferrous metals, non-ferrous metals and some non-metallic parts. It can be used for machining of inner and outer cylindrical surfaces, inner and outer conical surfaces, circular arcs, metric threads and various complex shapes.

VNL40S/H
VNL60S/H
VNL80S/H
VNL100S/H



- All structural parts are through finite element analysis and structural optimization to ensure the accuracy stability of the machine tool when cutting, And the machine mechanical rigidity is increased by 30% compared with the traditional design.
- VNL40/60/80/100 series all adopt C3 class precision ball screw, improve the positioning accuracy & repeat positioning accuracy.
- High rigid spindle unit, compact design with built-in hydraulic cylinder in spindle pulley, effectively reducing the overall height.

High class heavy-duty roller linear guideway

High bearing capacity, high precision, eliminating low-speed creeping motion, suitable for heavy cutting and high-speed cutting.

High-quality C3 class high speed silent ball screw

The pre-stretching structure of the lead screw is adopted to ensure the high transmission rigidity, reduce the thermal deformation, improve the positioning accuracy & repeat positioning accuracy.

Large angle slant bed design

The chips can be flushed by the coolant into the chip conveyor easily.

Special square base design

High stability, high rigidity, low thermal deformation, low vibration. The side way chip conveyor can be equipped according to different requirement

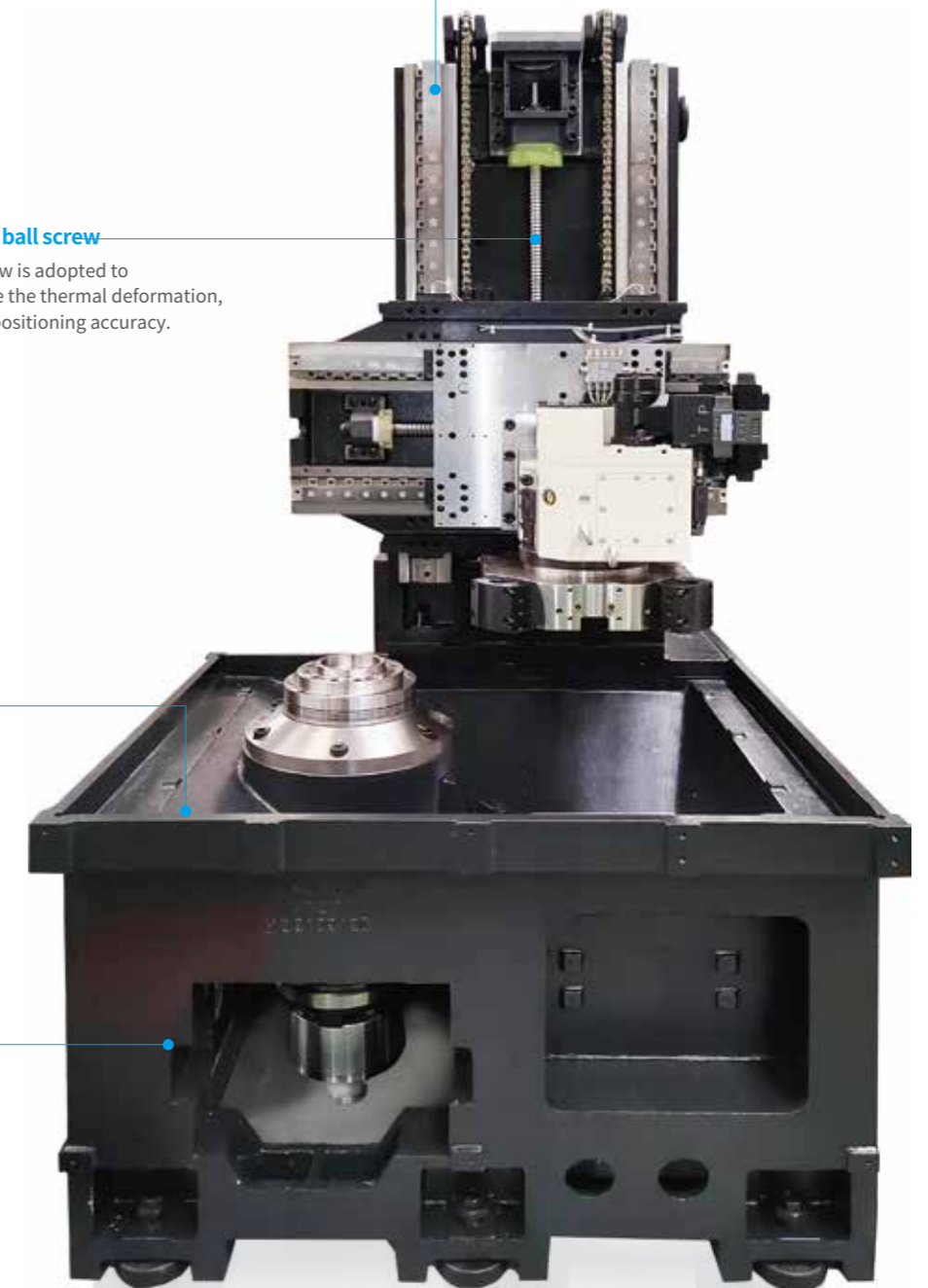

Main transmission system

- The spindle adopts high-rigidity and high-precision imported special spindle bearings, which can withstand radial load, axial load and moment load, ensure machining accuracy under heavy cutting conditions for a long time, and effectively extend the service life of the machine tool;
- The spindle adopts a flange structure and is fixed on a high-rigidity box base to minimize the influence of thermal deviation and vibration;
- The spindle components of each machine are tested for dynamic balance, which guarantees the high-precision cutting of the machine;
- Special labyrinth seal protection cover to prevent dust or coolant enter into spindle to make it broken.



ZF two-speed gearbox has two speed output, which can meet the requirements of low-speed and heavy-cutting of large-diameter workpieces, and also can meet the high speed machining requirements of small-diameter workpieces.

High speed(1:1)
Low speed(1:5.5)

Power drive configuration

- When machining large diameter workpieces, the spindle needs turn at low speed. Equipped with two-speed spindle motor or two-speed gearbox, so that the machine has high-speed/low-speed cutting capability at the same time;
- S series comes standard with China made servo motor:
VNL50S comes standard with low speed and high torque China made servo motor.
VNL65S/80S comes standard with China made two-speed spindle servo motor (optional two-speed gearbox);
- H series comes standard with imported servo main motor, VNL65H/80H comes standard with two-speed gear box;
- Special configurations can be realized according to customers' requirements, such as bigger spindle motor or cancel the gearbox.

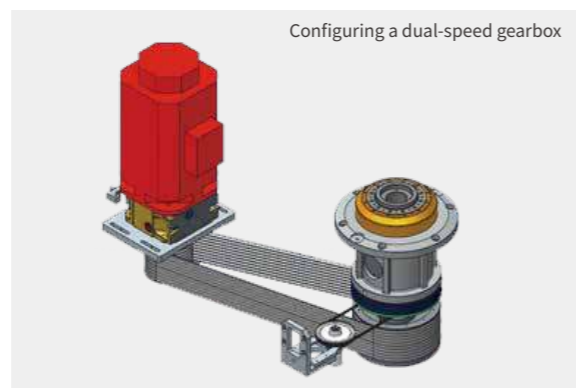
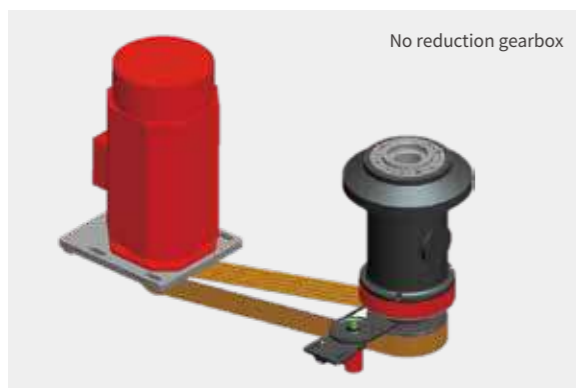

Turret

High rigidity and high reliability, strong processing adaptability, fast tool change and high processing efficiency.



Chuck

Hydraulic chuck as standard, automatically clamps the workpiece, and the clamping force is stable and adjustable; quick parts clamping to realize high production efficiency.

Common chuck configuration list				
Model	Chuck type	Specifications (inch/mm)	Spindle speed S/H(r/min)	Remarks
VNL40	Hydraulic chuck	12"	2500	Standard
		15"	2000	Optional
		18"	2000	
	Manual chuck	320	1200	Optional
400		1000		
VNL60	Hydraulic chuck	15"	1500(S)/2000(H/M)	Standard
		18"	1500(S)/2000(H/M)	Optional
		21"	1500	
	Manual chuck	400	1000	Optional
500		800		
VNL80	Hydraulic chuck	18"	1500(S)/2000(H/M)	Standard
		21"	1500	Optional
		24"	1250	
	Manual chuck	32"	800	
		500	1000	
		630	600	
VNL100	Hydraulic chuck	800	500	Optional
		21"	1500	
		24"	1250	
	Manual chuck	32"	800	
		500	1000	
		630	600	
		800	500	
		1000	400	



Spindle power torque diagram

(Unit: mm)

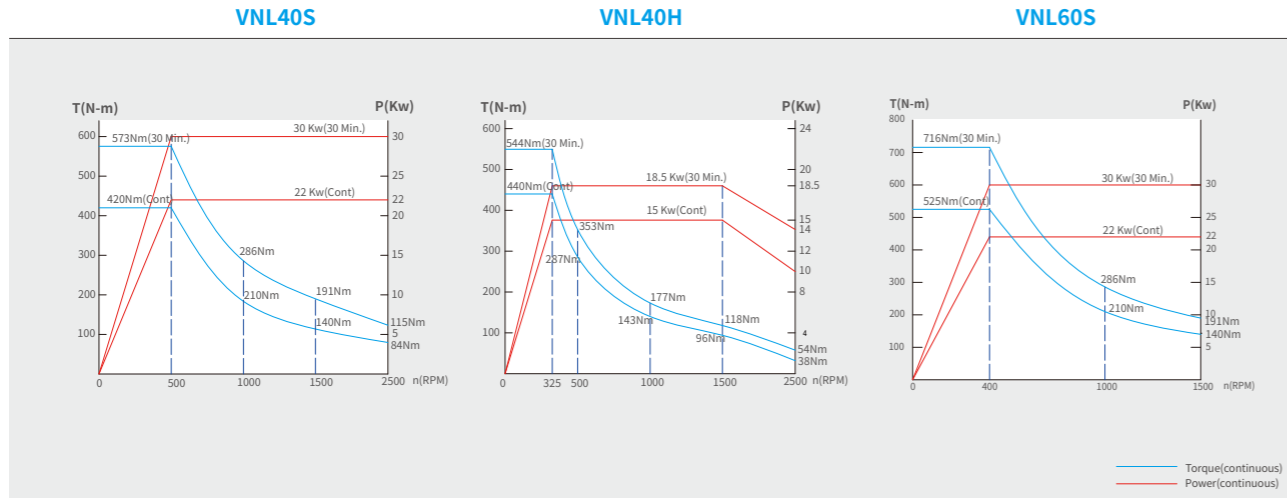

VNL100S (low speed)

VNL100H (high speed)

VNL100H (low speed)

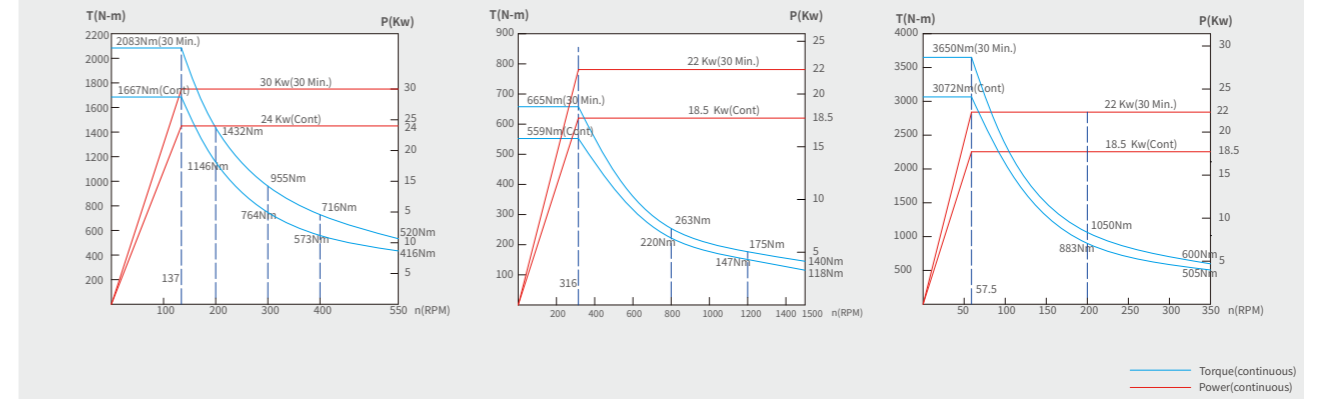

Tool interference diagram

(Unit: mm)

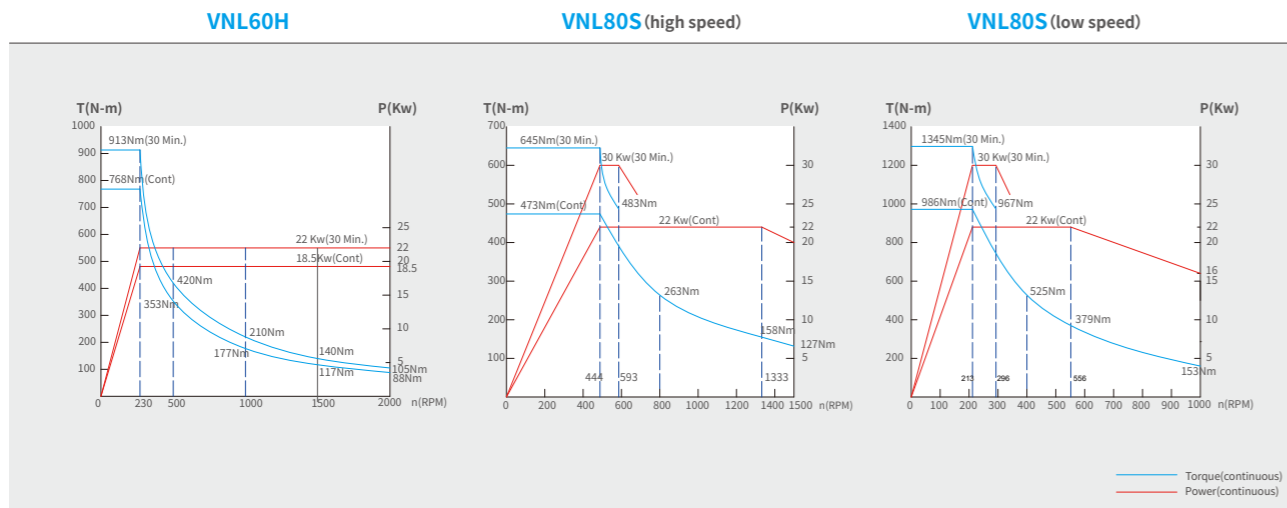

VNL40S/VNL40H

VNL60S/VNL60H/VNL80S/VNL80H

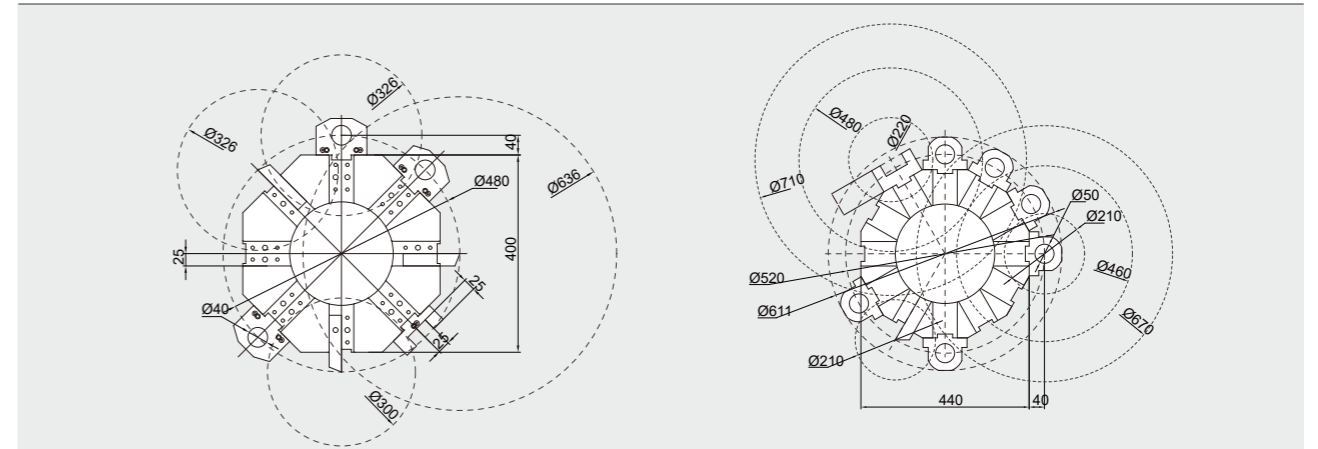

VNL80H (high speed)

VNL80H (low speed)

VNL100S (high speed)

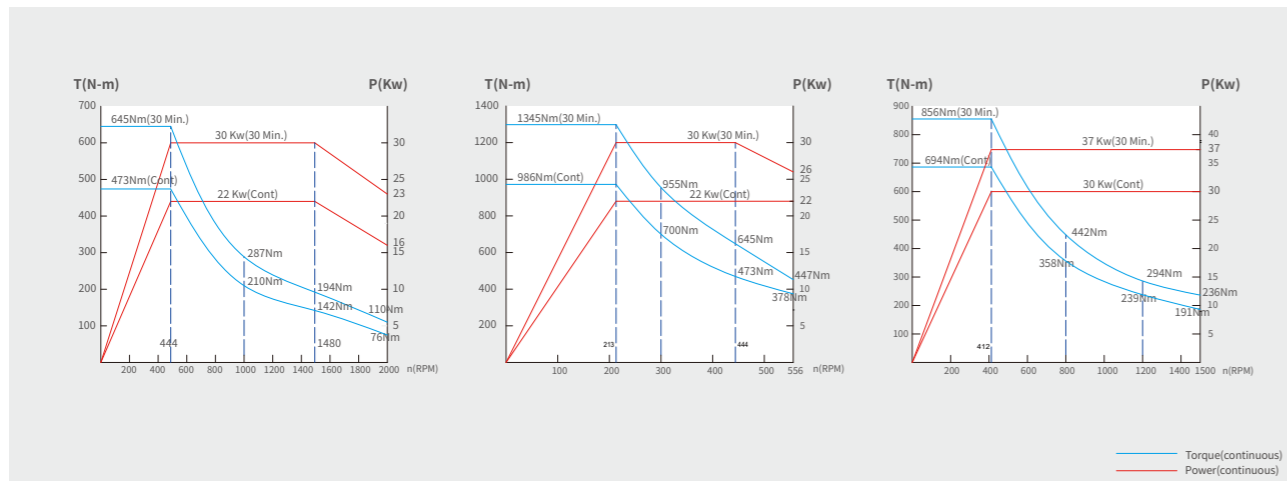

VNL100S/VNL100H

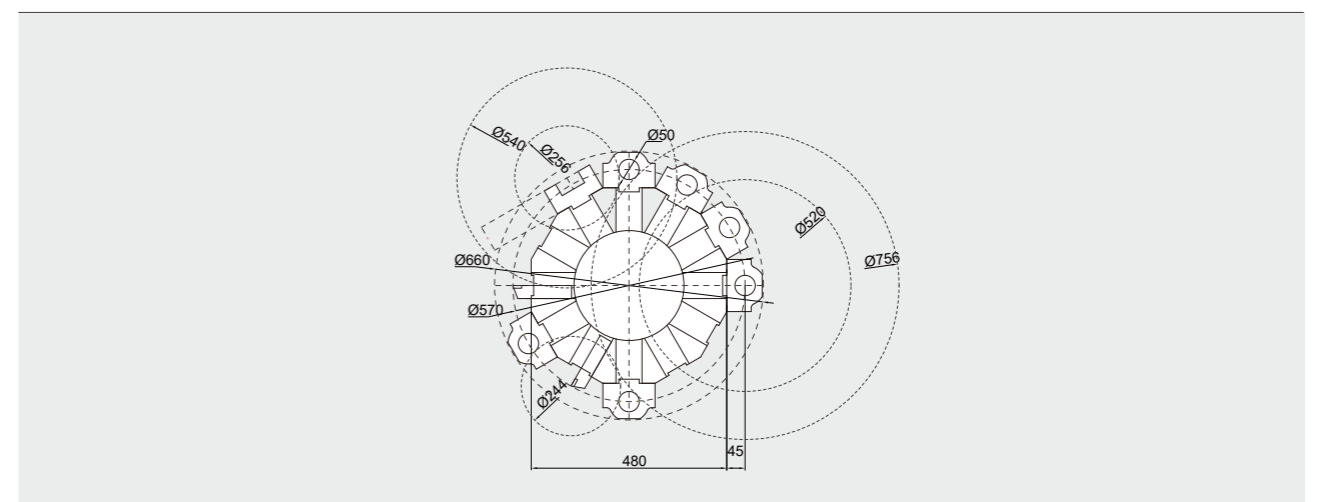

Machining area diagram

(Unit: mm)

VNL40S/H

VNL60SA/HA, VNL80SA/HA, VNL100S/H

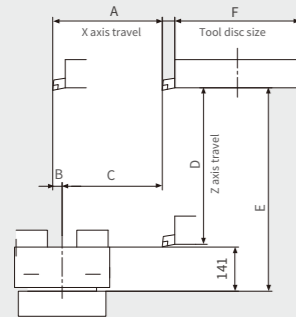

Horizontal 8-station Turret

Model	A	B	C	D	E	F
VNL40	350	30	320	500	650	400

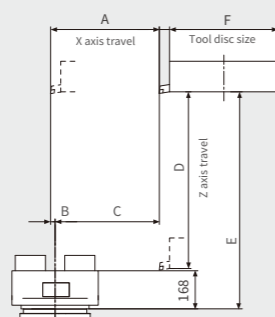

Horizontal 12-station Turret

Model	A	B	C	D	E	F
VNL60	420	20	400	620	798	440
VNL80	480	20	460	780	958	440
VNL100	520	20	500	859	1069	480

Model	A	B	C	D	E
VNL40	320	600	125	509	660
VNL60	570	780	130	630	950
VNL80	670	850	150	790	980
VNL100	800	1000	150	902	1100

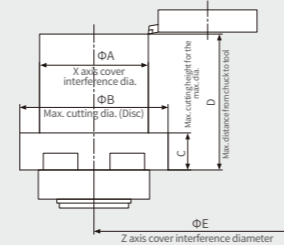

External dimensions

VNL40S/H, VNL60S/H, VNL80S/H, VNL100S/H

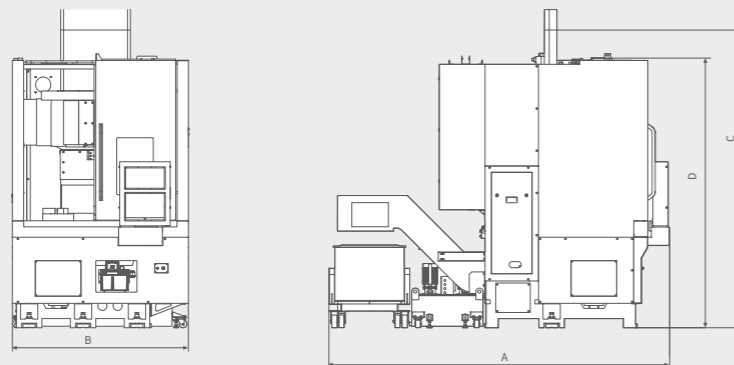

Model	A	B	C	D
VNL40S/H	3265	1730	2650	3130
VNL60S/H	3600	1900	2820	3400
VNL80S/H	3820	2050	3000	3600
VNL100S/H	4280	2350	3220	3710

Item	Unit	VNL40S/H	VNL40SY/HY	VNL60S/H	VNL60SY/HY	VNL80S/H	VNL100S/H	
Max. swing diameter	mm	Φ620	Φ620	Φ800	Φ800	Φ930	Φ1000	
Max. cutting diameter (Shaft)	mm	Φ320	Φ320	Φ550	Φ550	Φ650	Φ800	
Max. cutting diameter (Disc)	mm	Φ600	Φ600	Φ780	Φ780	Φ850	Φ1000	
Max. workpiece height	mm	460	400	610	500	770	800	
X/Z travel	mm	350/500	350/440/70 (X/Z/Y)	420/620	420/600/70	480/780	520/880	
X/Z axis rapid speed	m/min	20/20	20/20/15 (X/Z/Y)	16/16(S) 20/20(H)	16/16/15(SY) 20/20/15(HY)	16/16(S) 20/20(H)	12/12	
Main motor power	kW	24/30(S) 15/18.5(H)	22/30(SY) 15/18.5(HY)	22/30(S) 18.5/22(H)	22/30(SY) 18.5/22(HY)	22(30)	24/30(S) 15/18.5(H)	
Chuck size	inch/mm	12" (hydraulic chuck)		15" (hydraulic chuck)		18" (hydraulic chuck)	21" (hydraulic chuck)	
Spindle nose	-	A2-8	A2-8	A2-11	A2-11	A2-11	A2-15	
Spindle front bearing diameter	mm	130	130	160	160	160	200	
Max. spindle speed	r/min	2500	2500	1500/2000	1500/2000	1500/2000	1500	
Max. spindle torque	N.m	573/544	573/544	716/913	716/913	1345	2083/3650	
Tool position	-	8(Horizontal) [6(vertical)]	8(Horizontal)	12(Horizontal) [6(vertical)]	12(Horizontal)	8(Horizontal) [6(vertical)]	8(Horizontal) [6(vertical)]	
Turning tool shank size	mm	25×25	25×25	32×32	32×32	32×32	32×32	
Boring tool holder diameter	mm	Φ40	Φ40	Φ50	Φ50	Φ50	Φ50	
Driven type	-	Hydraulic (servo)	Hydraulic	Hydraulic (servo)	Hydraulic	Hydraulic (servo)	Hydraulic (servo)	
Positioning accuracy (X/Z)	mm	0.006/0.008	0.006/0.008/0.008(X/Z/Y)	0.008/0.012	0.008/0.012/0.008(X/Z/Y)	0.008/0.012	0.020/0.020	
Repeat positioning accuracy (X/Z)	mm	0.005/0.005	0.005/0.005/0.005(X/Z/Y)	0.006/0.008	0.006/0.008/0.005(X/Z/Y)	0.006/0.008	0.010/0.010	
CNC control system	-							
Auto chip conveyor	-	Rear (sideway)	Rear (sideway)	Rear (sideway)	Rear (sideway)	Rear (sideway)	Rear (sideway)	
Power capacity	kVA	35	35	35/40	40	35/40	45/40	
Dimension(L×W×H)	mm	1730×3265×3130		1900×3600×3400		2050×3840×3670	2350×4300×3710	
Machine weight	kg	6500	6500	8000	8200	9500	12000	

Standard configuration:

Solid hydraulic chuck, hydraulic turret, rear chip conveyor, chip cart, cooling system, chip flushing system, centralized lubrication system, hydraulic system, fully enclosed protection, clean air gun, work light, tri-color lamp, electric cabinet heat exchanger

Optional configuration:

Hard jaw, side chip conveyor, linear scale, automatic door, oil water separator, liquid level alarm, oil mist collector, two-stage pressure reducing valve, electronic door lock, water gun, scraper type chip conveyor, ZF gear box, electric cabinet air conditioner, vertical 6 station turret, 12 station living turret, various hydraulic chucks, various manual chucks

VNL Series- CNC Vertical Lathe

- This series of models adopts mechatronic vertical design, the overall layout is compact and reasonable, and the installation and maintenance are convenient;
- The base adopts a thermal symmetrical structure to overcome the influence of the temperature rise of the spindle on the machining accuracy;
- X/Z axis lead screw is pre-stretched structure, which can reduce the influence of temperature rise during machining on lead screw precision;
- The vertical structure avoids the roundness deviation caused by the gravity of the workpiece during horizontal clamping and ensures the roundness accuracy of the part;
- The weight of the workpiece ensures that the workpiece and the fixture are closely attached, so that the workpiece can obtain high positioning accuracy and machining accuracy;
- Suitable for valves, chemical, medical machinery and other industries. They can finish the processing of various type parts with complex shapes, such as large, heavy and thin

VNL125S/H/SK/HK

VNL160S/H/SK/HK



- The machine adopts high torque spindle motor, standard Germany ZF gear box. It realizes a wide range of spindle speed regulation and high torque heavy cutting;
- The column adopts a special closed box structure to improve the overall stability of the machine tool and provide strong support for heavy cutting;
- The main castings are made of high grade cast iron after aging treatment to ensure the accuracy and stability of the machine;
- The beam movement adopts hierarchical positioning to ensure that the processing can be finished within the shortest length of the ram and improve the machining accuracy.

Lead screw pre-stretching structure

The X/Z axis lead screw are all with pre-stretching structure, which can reduce the influence of the temperature rise on the precision of the lead screw during the machine running, and ensure the excellent precision stability.

Unique roller & box composite guideway design

The guide direction surface is linear guideway with small friction force and reduced specific pressure; the bearing direction is box guideway, which has good anti-vibration performance and large bearing capacity. This structure can achieve long-term stable precision and good vibration damping effect.

Strong main structure

The main castings are made of high-grade gray cast iron to guarantee the high stability of the machine, provides strong support for heavy cutting and improve the accuracy of the machine.

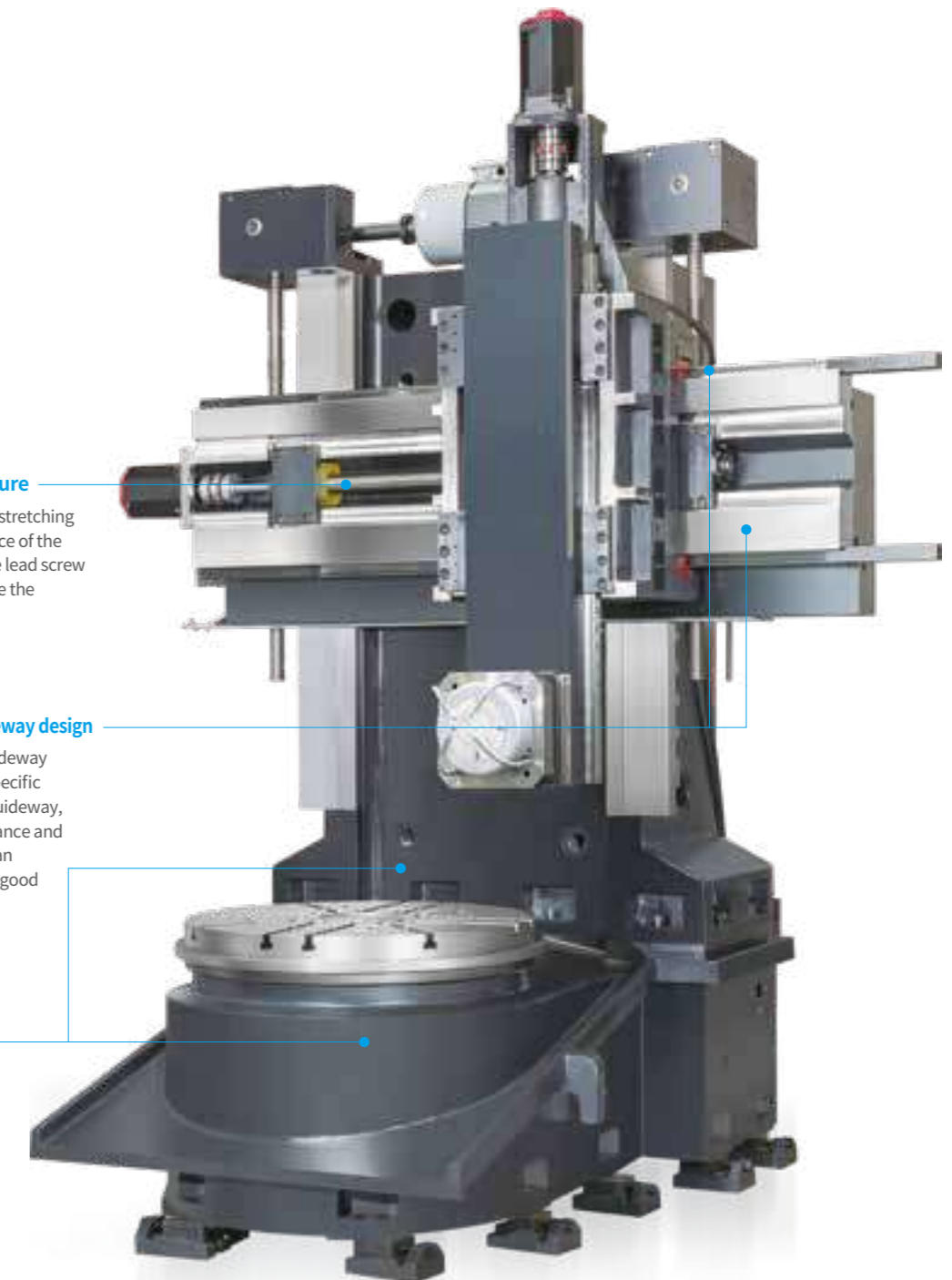



Base

- The base adopts a thermal symmetrical structure to overcome the influence of the temperature rise of the spindle on the machining accuracy;
- The base is made of high quality cast iron HT300, high strength, good vibration absorption, and secondary aging to ensure stable accuracy;
- The finite element analysis and optimization design of the reinforce rib make the machine have high rigidity;
- ZF gear box and motor are mounted on the backside for easy maintenance and repair.

Guideway structure

- Linear guideway and box guideway are used together to ensure long-term stability and heavy cutting performance;
- Adopts linear way on guide direction to realize small friction and reduces the specific pressure, and guarantee long-term running accuracy remaining unchanged;
- Adopts plastic coated box way on bearing direction for good anti-vibration performance, large load capacity and reduced friction coefficient.



Beam lifting system

- Using the worm gear drive the lead screw to make the beam move up and down, compact structure, large transmission ratio and reliable transmission;
- The beam can be moved up and down, and the processing range is large, ensuring that the machine tool has the best rigidity when processing parts with different heights;
- The beam movement by grade, which is controlled by PLC, simple operation and reliable movement;
- Special assembly process to ensure the geometric accuracy of the beam at each position.

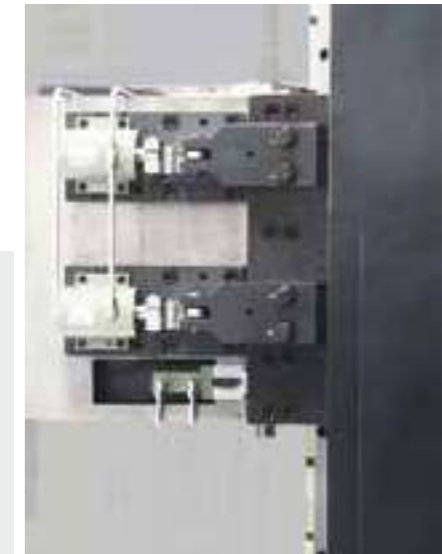

Tool change system

- VNL125S/H, VNL160S/H with electric square turret as standard, high positioning accuracy, large locking force, strong bearing capacity, stable and reliable;
- VNL125SK/HK, VNL160SK/HK adopt the drum type tool magazine; auto tool changing to improve the machining efficiency;
- BT50 taper, standard with 3 turning tool holder and 1 boring tool holder;
- Special assembly technology ensures the geometric accuracy of the beam at any position.



Spindle power torque diagram

(Unit:mm)

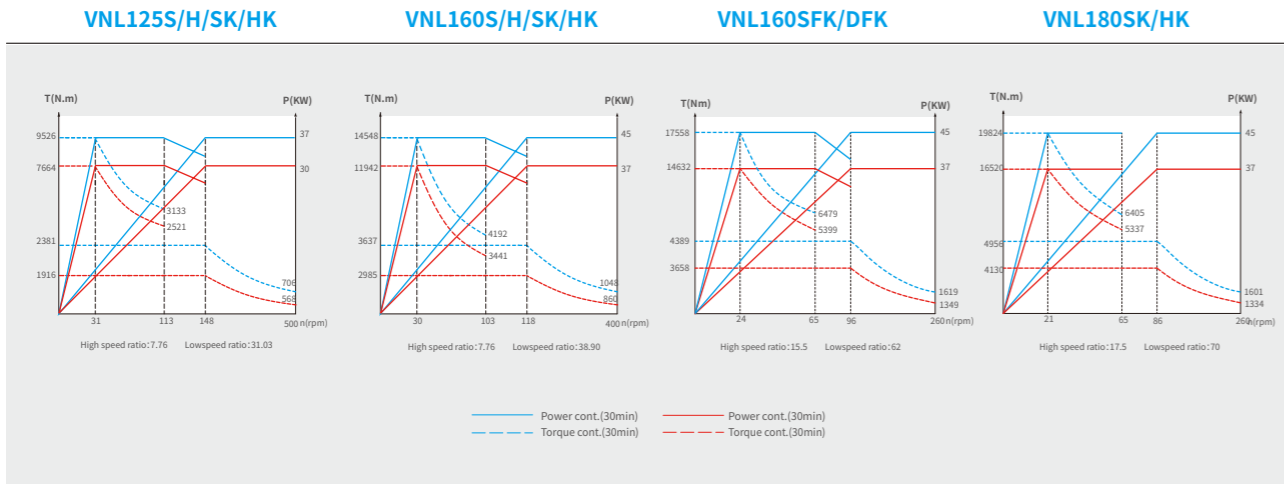

Machining area diagram

(Unit:mm)

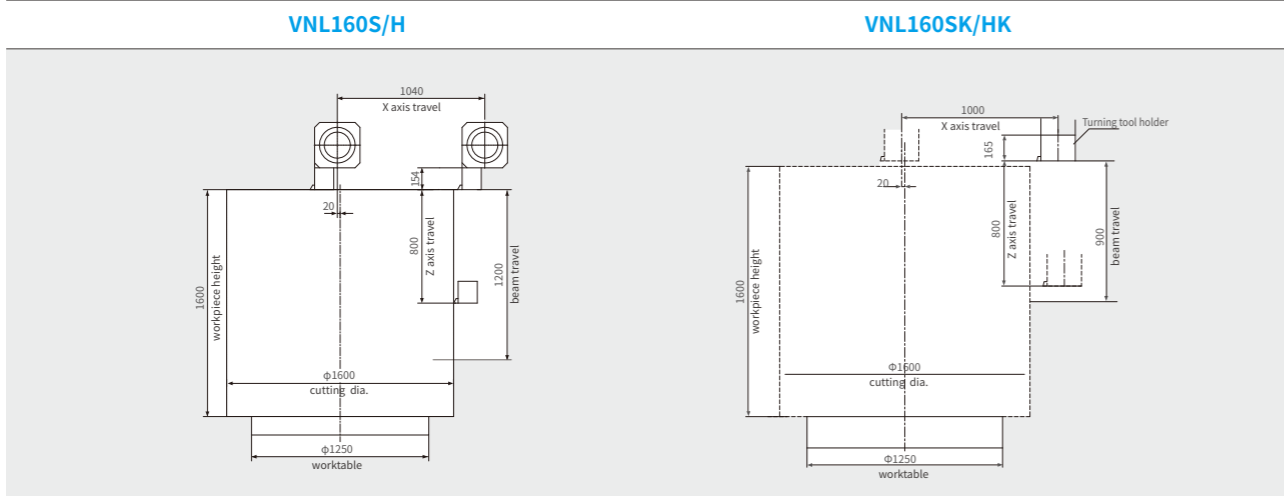
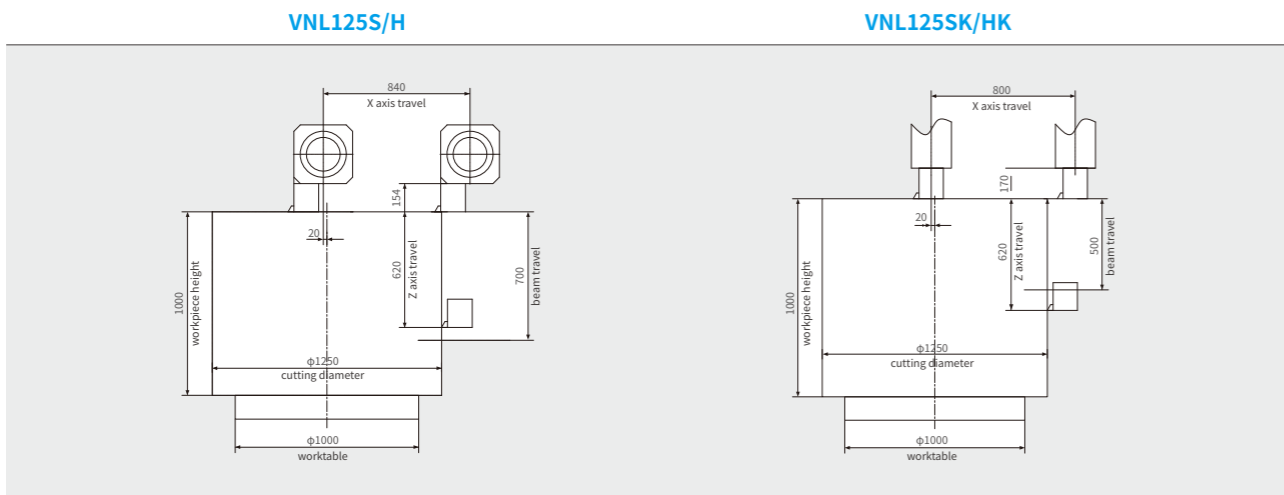

VNL160SFK/DFK

VNL180SK/HK

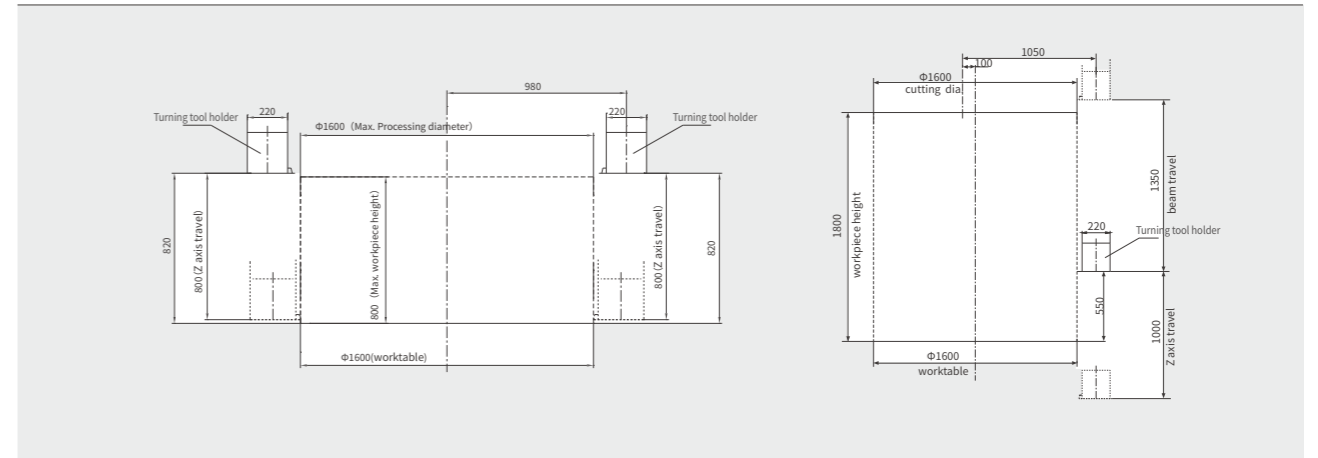

Ram interference diagram

Tool Interference diagram

VNL125, 160, 180SK/HK

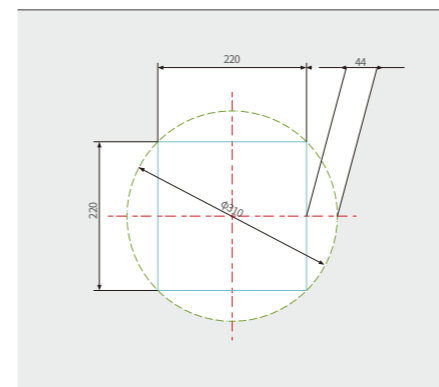

VNL125SK/HK

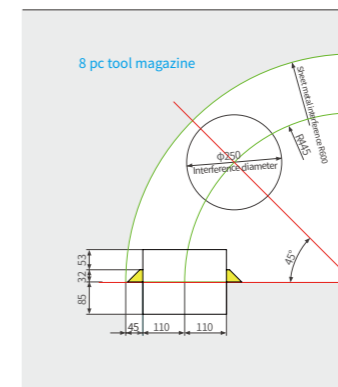

VNL160, 180SK/HK

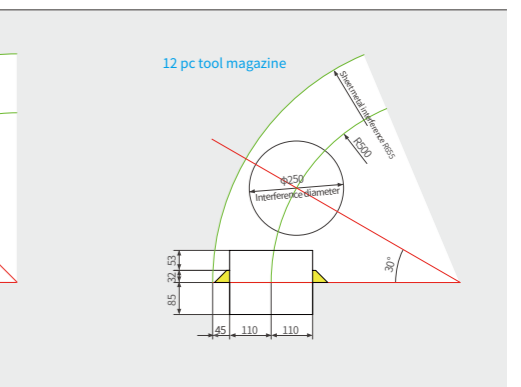

Worktable external dimension

VNL125S/H/SK/HK

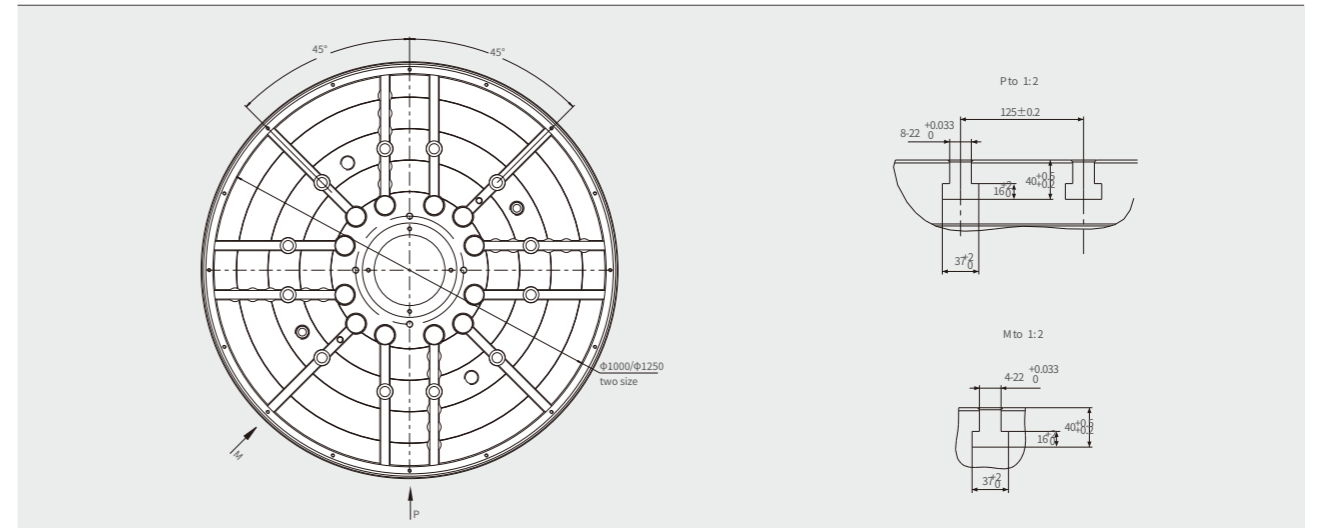

Worktable external dimension

(Unit:mm)

VNL160S/H/SK/HK, VNL180SK/HK

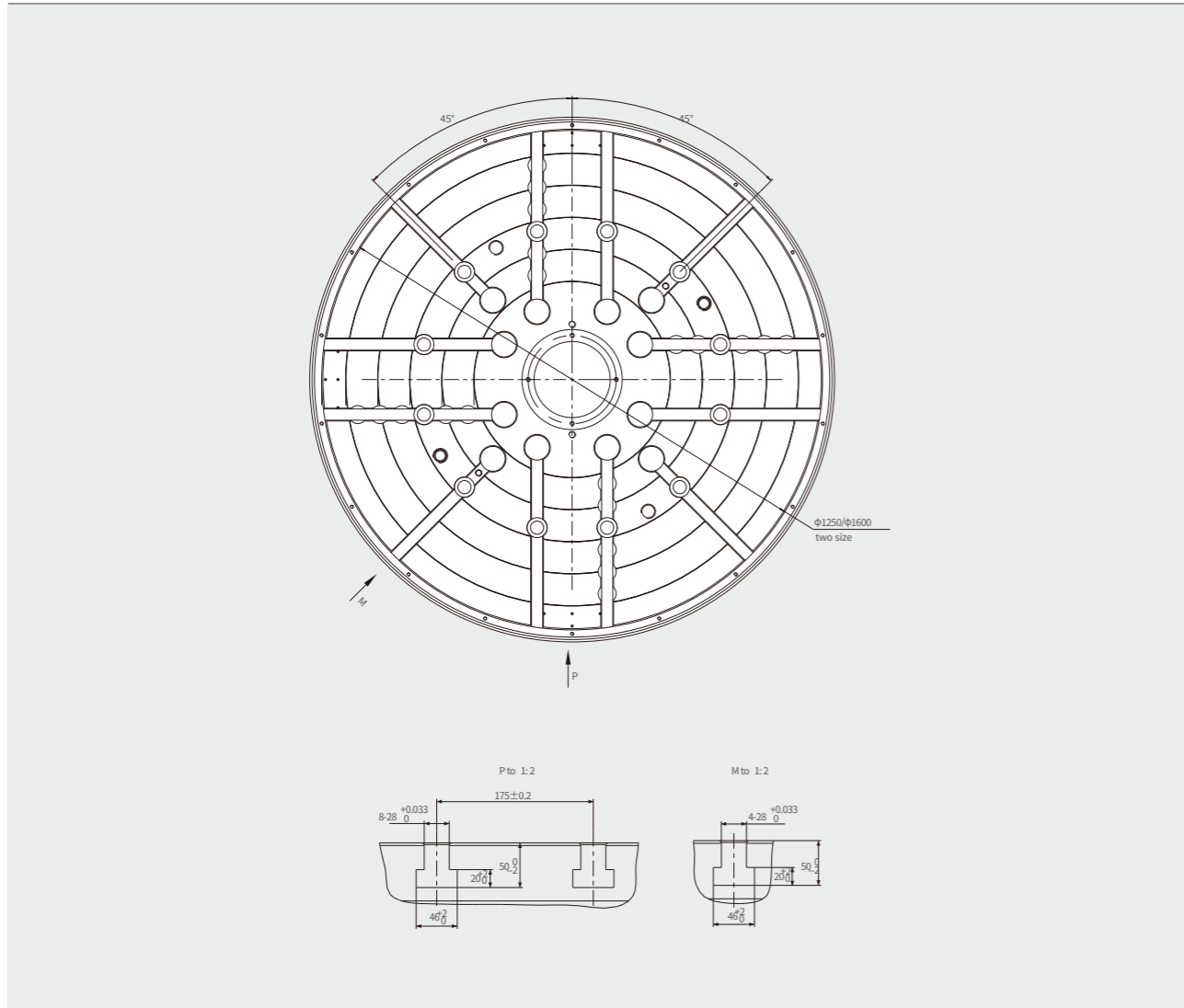

Boring tool holder

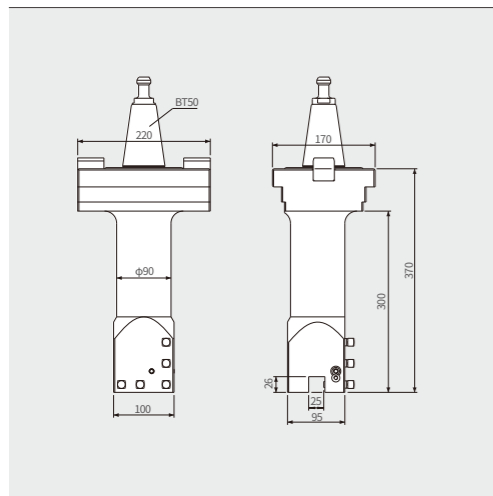

Turning tool holder

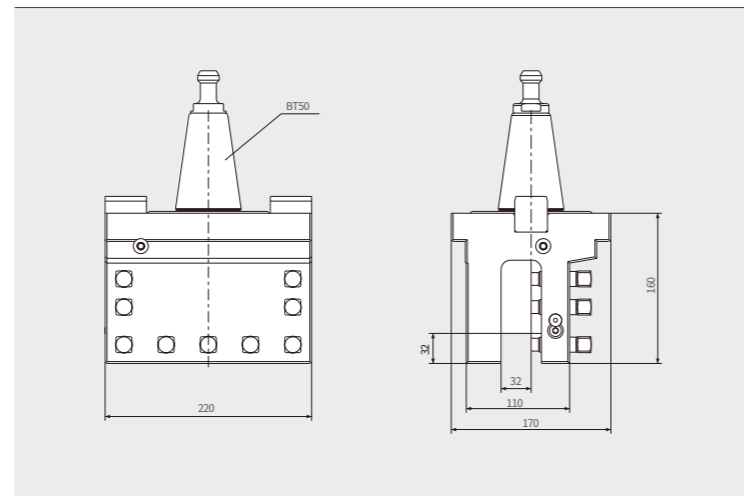

External dimensions

(Unit:mm)

VNL125S/H/SK/HK

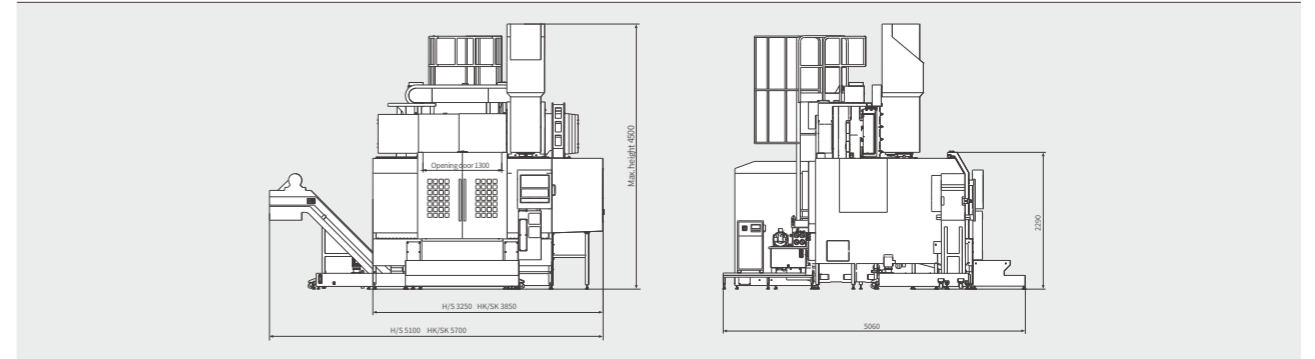

VNL160S/H/SK/HK

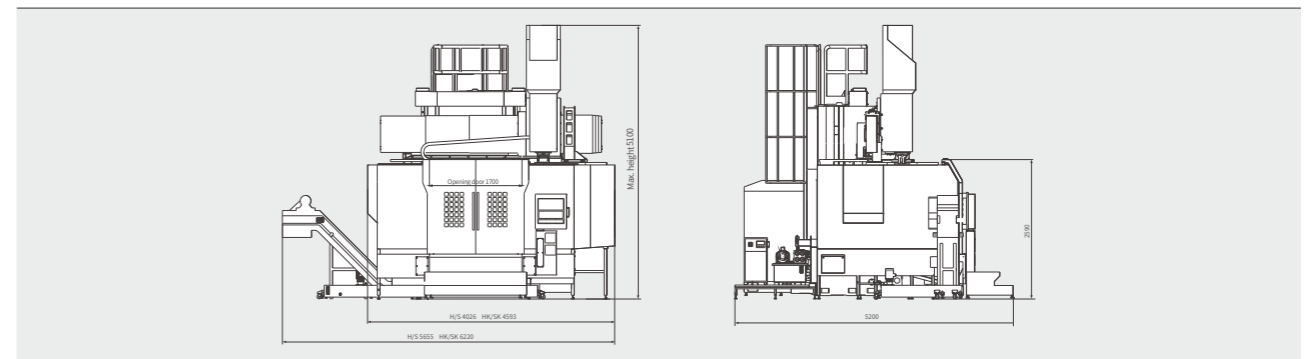

VNL160SFK/DFK

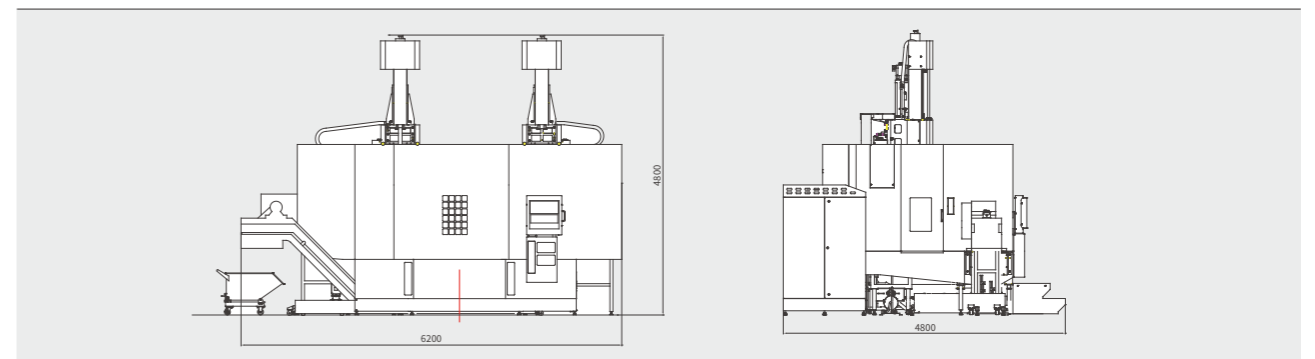

VNL180SK/HK

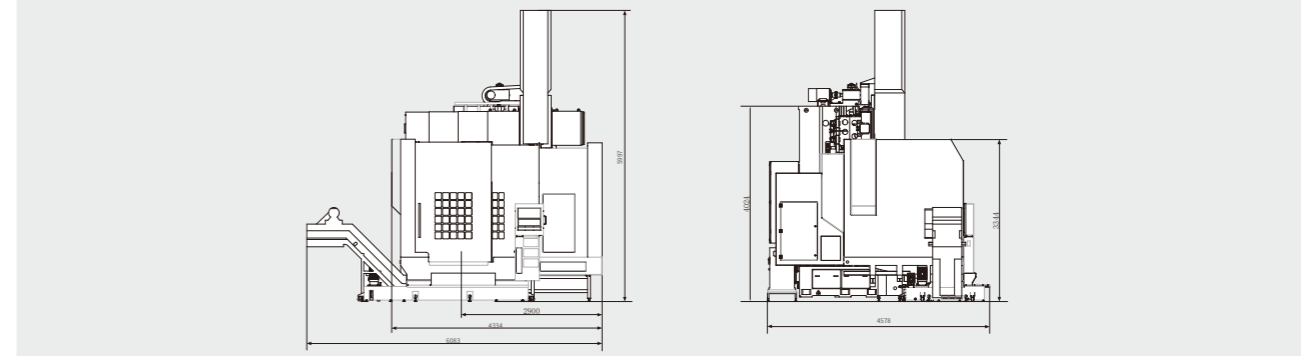

Item		Unit	VNL125S/H	VNL125SK/HK	VNL160S/H	VNL160SK/HK	VNL160SFK/DFK	VNL180SK/HK
Cutting capacity	Max. swing diameter	mm	Φ1500	Φ1500	Φ1800	Φ1800	Φ1800	Φ1800
	Max. cutting diameter	mm	Φ1250	Φ1250	Φ1600	Φ1600	Φ1600	Φ1600
	Max. workpiece height	mm	1000	1000	1600	1600	800	1800
	Max. workpiece weight	kg	5000	5000	8000	8000	8000	8000
Travel	X/Z travel	mm	840/620	800/620	1040/800	1000/800	980/800	1050/1000
	X/Z axis rapid travel speed	m/min	12/12	(SK)10/10 (HK)12/10	12/12	(SK)10/10 (HK)12/10	(SK)10/10 (HK)12/10	(SK)10/10 (HK)12/10
Spindle	Main motor power	kW	30(cont.)	30(cont.)	37(cont.)	37(cont.)	37(cont.)	37(cont.)
	Worktable diameter	mm	Φ1000	Φ1000	Φ1250	Φ1250	Φ1250	Φ1600
	Max. worktable speed	r/min	500	500	400	400	260	260
	Max. worktable torque	N.m	9000	9000	S12500/H14000	S12500/H14000	17000	19000
Turret	Tool position	-	4(vertical)	8(tool magazine)	4(vertical)	12(tool magazine)	12(tool magazine)	12(tool magazine)
	Turning tool shank size	mm	32×32	32×32	32×32	32×32	32×32	32×32
	driven type	-	electric	electric	electric	electric	electric	electric
	Servo motor torque	N.m	S36/36 H30/38	SK36/36 HK30/38	S36/36 H30/38	SK36/36 HK30/38	SK36/36 HK30/38	S36/36 H30/38
Machine accuracy	Positioning accuracy (X/Z)	mm	0.020/0.020	0.020/0.020	0.020/0.020	0.020/0.020	0.020/0.020	0.020/0.020
	Repeat positioning accuracy (X/Z)	mm	0.015/0.015	0.015/0.015	0.015/0.015	0.015/0.015	0.015/0.015	0.015/0.015
Others	CNC control system	-	NEWAY FANUC[SIEMENS]					
	Dimension (L×W×H)	mm	5100×5060×4500	5700×5060×4500	5655×5200×5100	6220×5200×5100	6200×4800×4800	6220×5200×5100
	Auto chip conveyor	-	side way	side way	side way	side way	side way	side way
	Machine weight	kg	16000	17000	25000	26000	29000	30000

Standard configuration:

Auto chip conveyor, lubrication device, hydraulic system, machine guard, air gun, tri-color lamp, work light, chip cart, foot pedal, standard tool holder.

Optional configuration:

Linear scale, tool setter, workpiece measurement probe, water gun, oil-water separator, liquid level alarm, electric cabinet air conditioner, special tool holder.

VNL Series- Double Column CNC Vertical Lathe

- This series of models adopts the full cast structure design of column-type, has higher stability;
- Symmetrical structural design to reduce the influence of spindle temperature rise on accuracy;
- The column is fixed on the base and the foundation at the same time to realize higher rigidity of the whole machine;
- The beam movement adopts multi-grade positioning to ensure the machining within the shortest length of the ram, improve the machining accuracy;
- VNL250H/250HK series is equipped with double tool post, which can be used for roughing and finishing at the same time to improve machining efficiency.



The integral structure

The fully symmetrical gantry structure of the left and right vertical columns is used to effectively control the influence of thermal deformation on the accuracy of the machine. The column is fixed on the base and the foundation to greatly improve the overall rigidity of the machine. The four large-sections rectangular guideway design on the column ensure high precision and high stability. The main components, such as the base, worktable, column and beam, are all made of high-strength cast iron, which ensures the stability, rigidity and precision retention of the machine.

Hydraulic counterweight system

Effectively balances the gravity load to ensure that the machine responds quickly and maintains good geometric accuracy under all conditions.

Double column symmetrical structure

It overcomes the influence of the temperature rise of the spindle on the machining accuracy; the column is made of high-quality cast iron HT300, after the secondary aging treatment to ensure the accuracy stability.

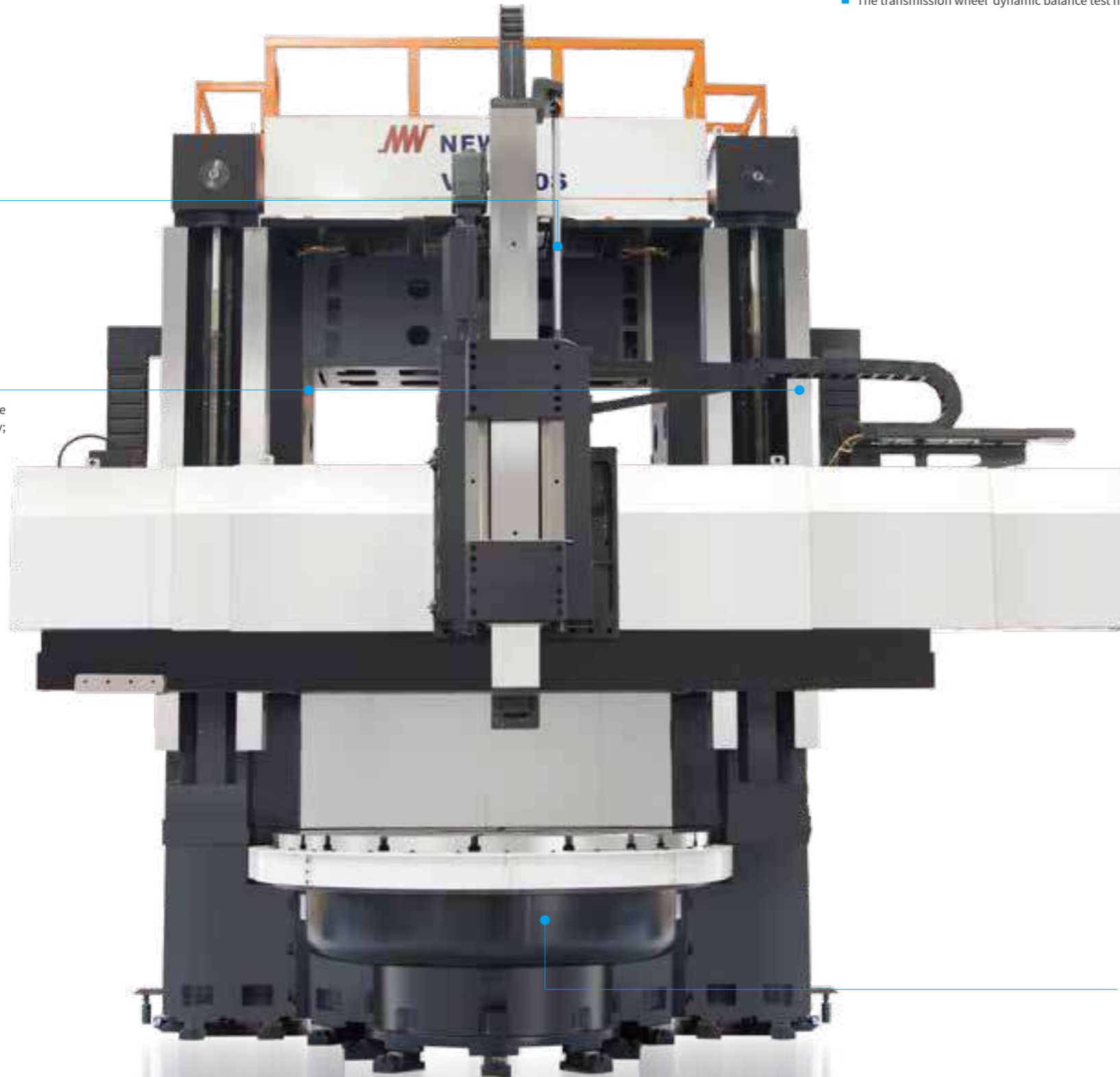

Main transmission structure

- Adopting a completely symmetrical structure to effectively control the influence of thermal deformation on machine tool accuracy;
- The large gears are made of high-grade alloy steel, which is made by appropriate heat treatment and high-precision gear grinding machine to minimize the running noise of the spindle;
- Thrust ball bearing with external diameter of 1250mm, which makes the load capacity of the machine tool up to 16 tons;
- The transmission wheel dynamic balance test minimize the vibration of the machine during high-speed running and ensure the roughness of the machined parts.



Powerful cutting capacity

The spindle adopts 55kW AC variable frequency motor with rated speed of 750rpm, which can carry out heavy cutting at lower speed. After multi-stage gearbox deceleration, the maximum torque of the table reaches 40,000N.m

Solid foundation design

The base adopts a thermal symmetrical structure, which overcomes the influence of the temperature rise of the spindle on the machining accuracy. The base is made of high-quality cast iron HT300, after the secondary aging treatment to ensure the accuracy stability. The finite element analysis and optimization design of the base reinforce ribs make the machine tool have high rigidity.

Clamping range diagram

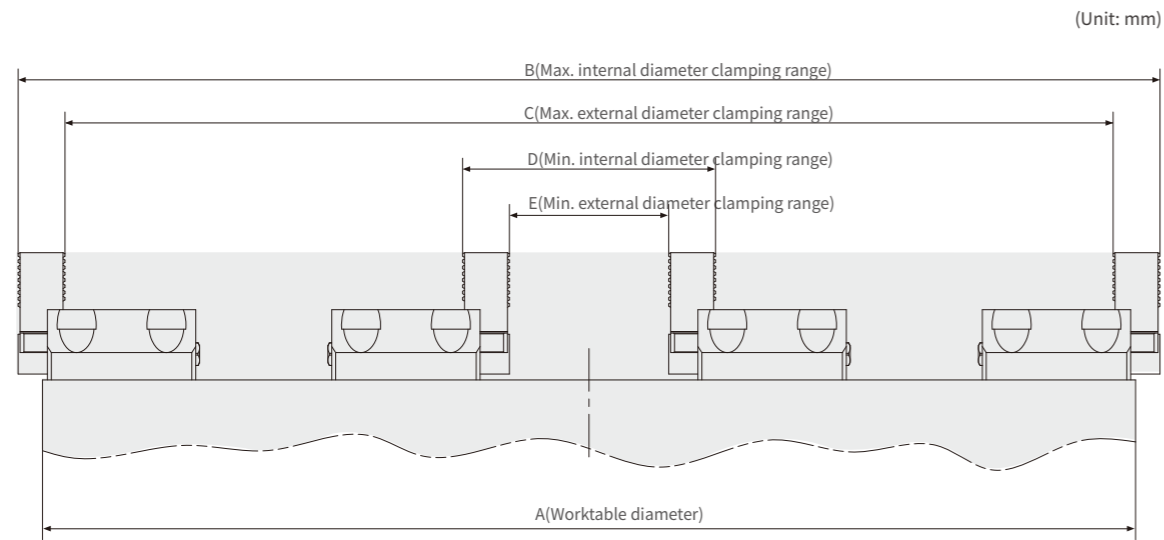

Model	A	B	C	D	E
VNL125	1000	1070	940	290	170
	1250	1270	1140	290	170
VNL160	1250	1395	1255	335	195
	1600	1655	1515	335	195
VNL250	2250	2415	2200	715	500
	2500	2575	2365	715	500
VNL400	3600	3780	3580	1060	860
VNL500	4500	4660	4460	980	780

Spindle power torque diagram

(Unit: mm)

VNL250S/D/SK/DK/SF/DF/SFK/DFK

VNL400S/D/SK/DK/SFK/DFK

VNL500S/H/SK/HK

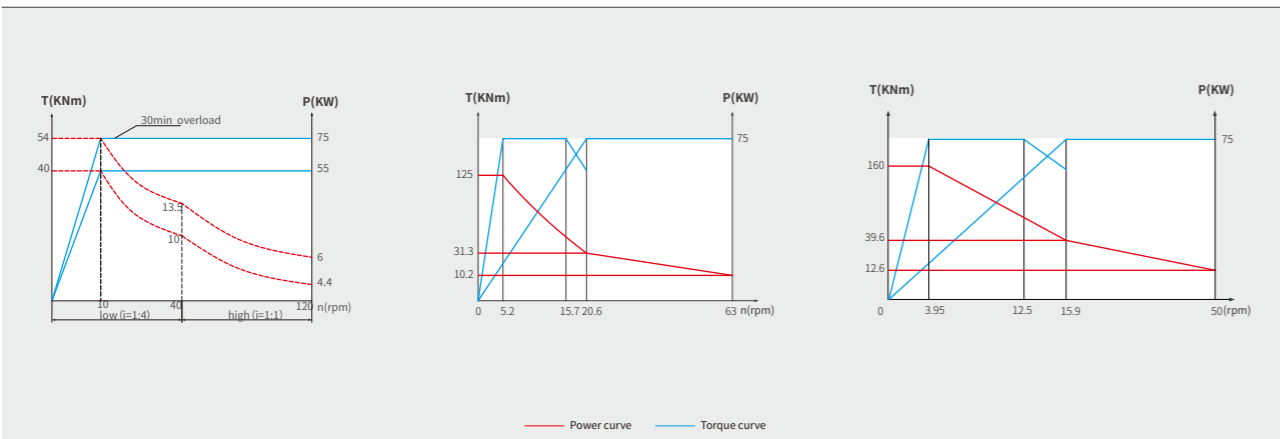

Machining area diagram

(Unit: mm)

VNL250S/SK

VNL250D/DK

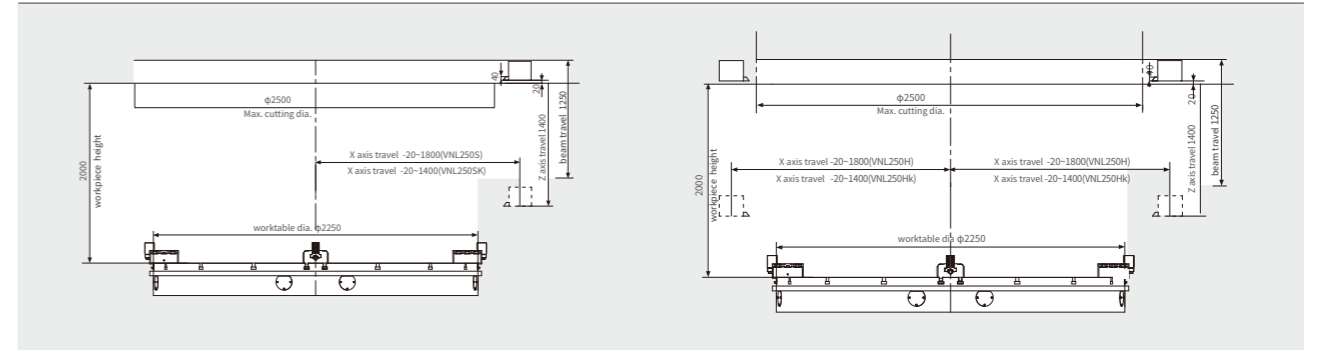

VNL250H/HK

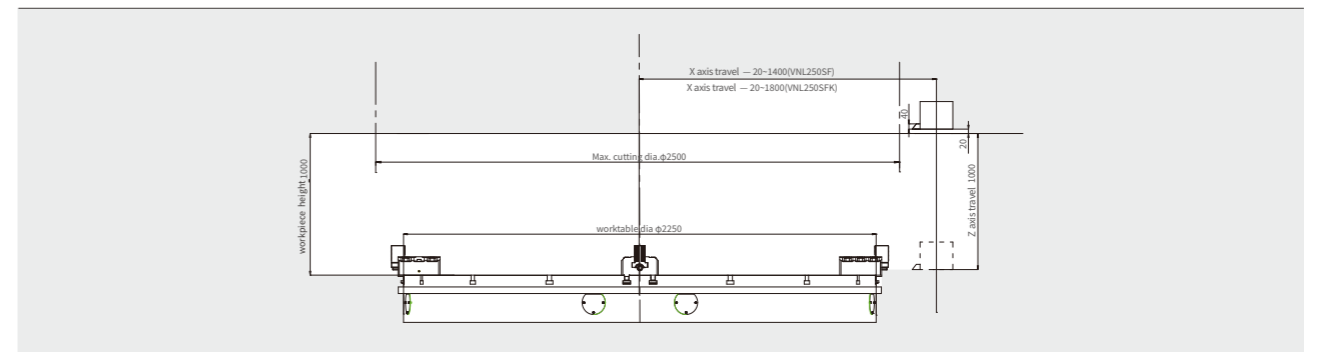

VNL400S/SK

VNL400D/DK

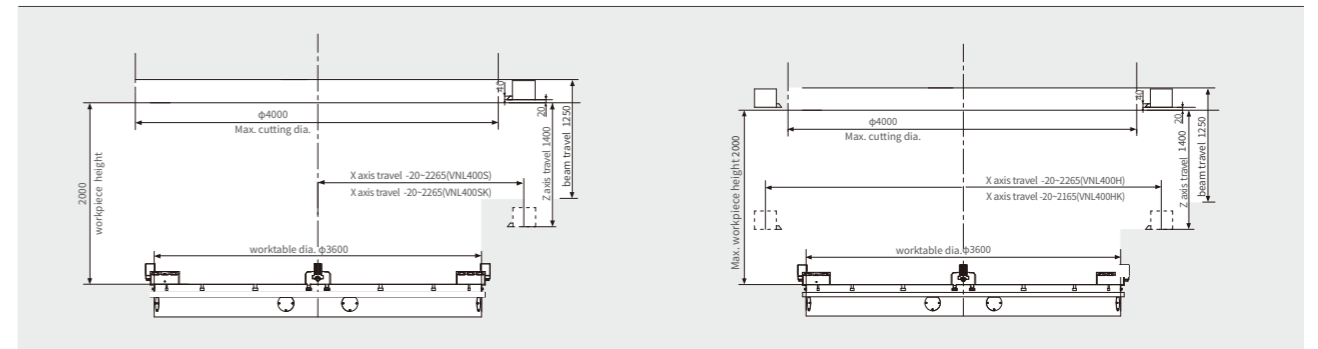

VNL400SF/SFK

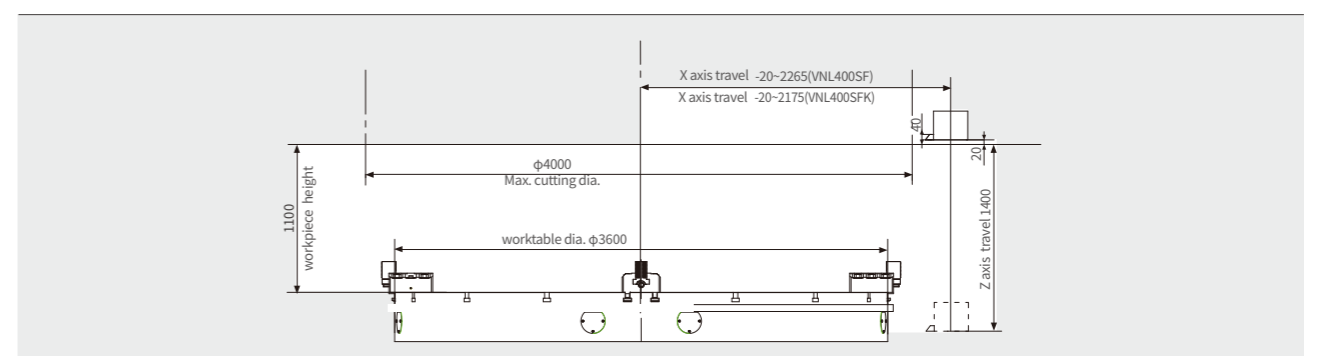

Machining area diagram

(Unit: mm)

VNL250DF/DFK

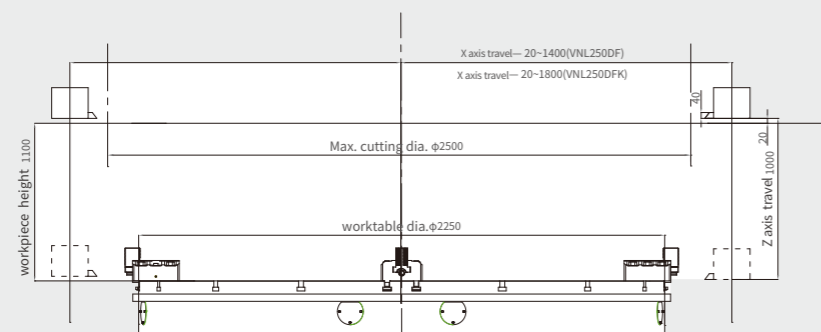

VNL400DF/DFK

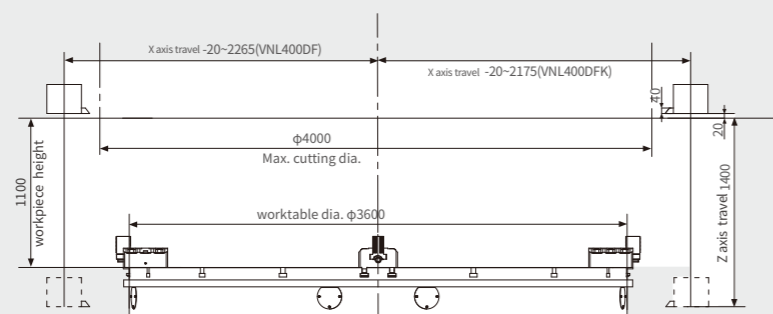

VNL500S/SK

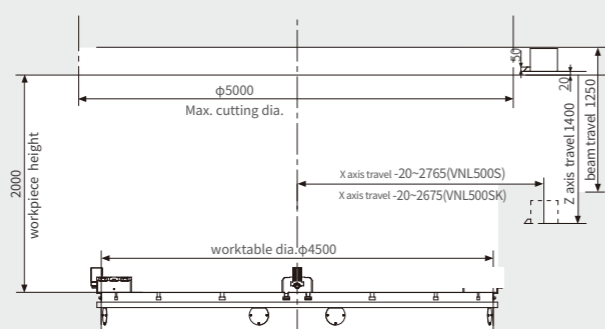

VNL500H/HK

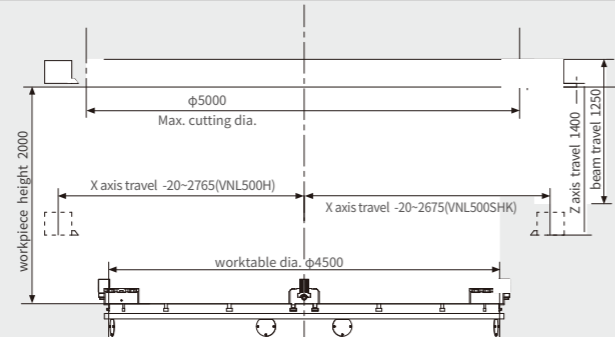

External dimensions

(Unit: mm)

VNL250S/SK

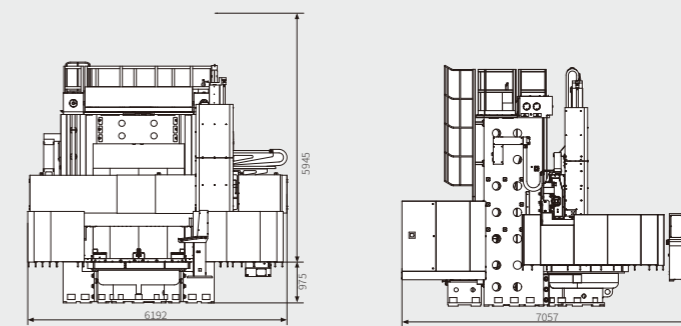

VNL250SF/SFK

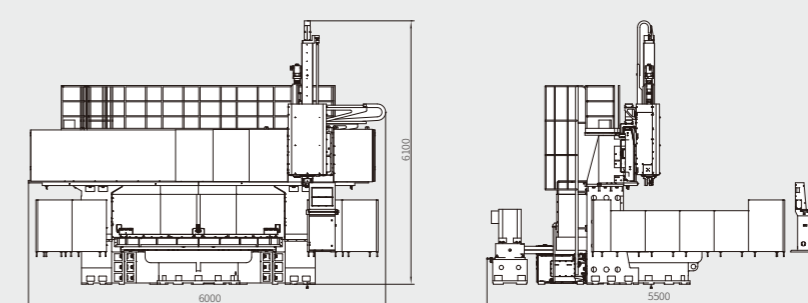

VNL250D/DK

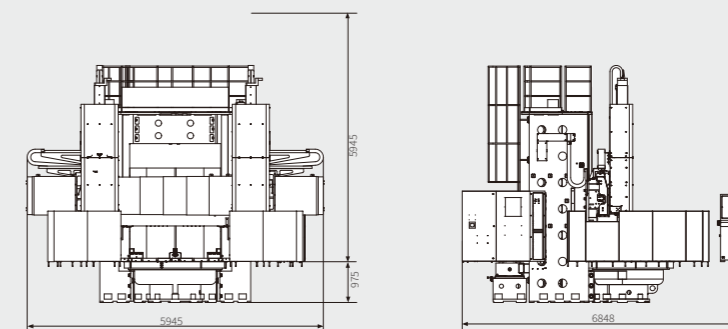

VNL250SFK/DFK

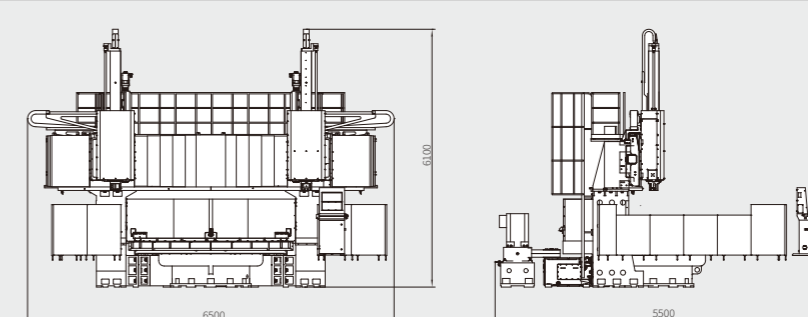

External dimensions

(Unit: mm)

VNL400S/SK

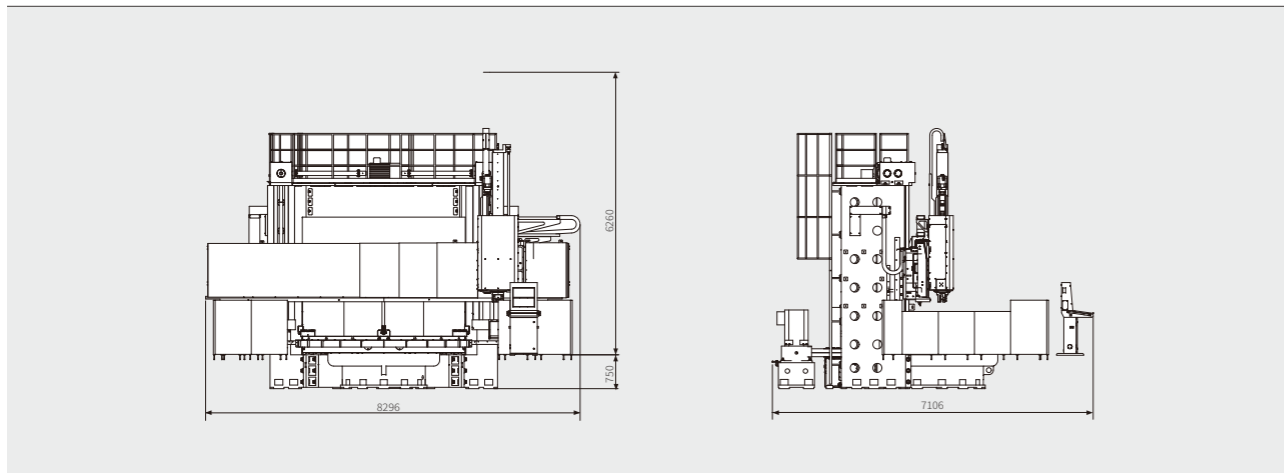

VNL400D/DK

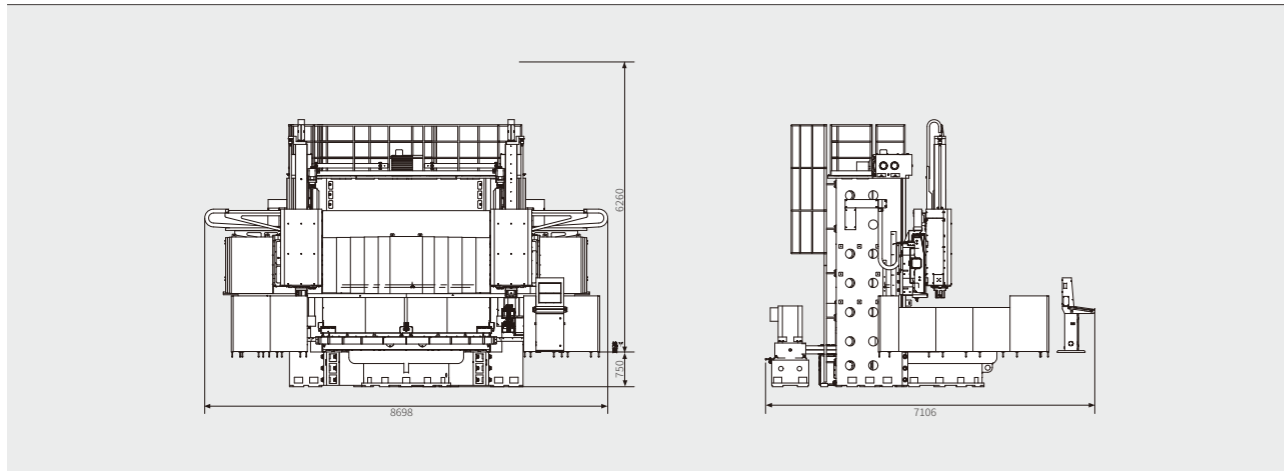

VNL400SF/SFK

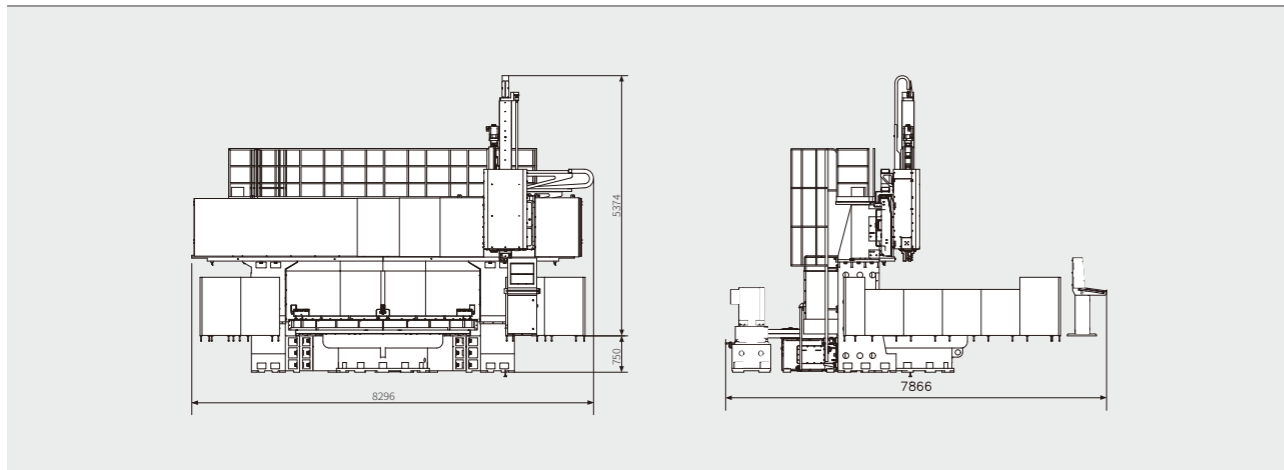

VNL400DF/DFK

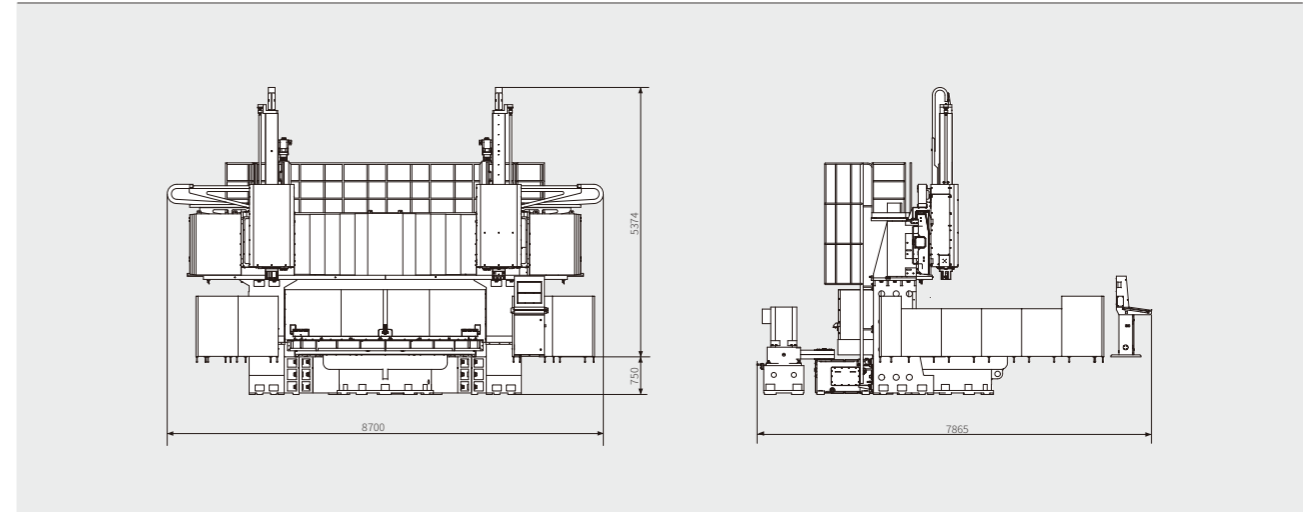

VNL500S/SK

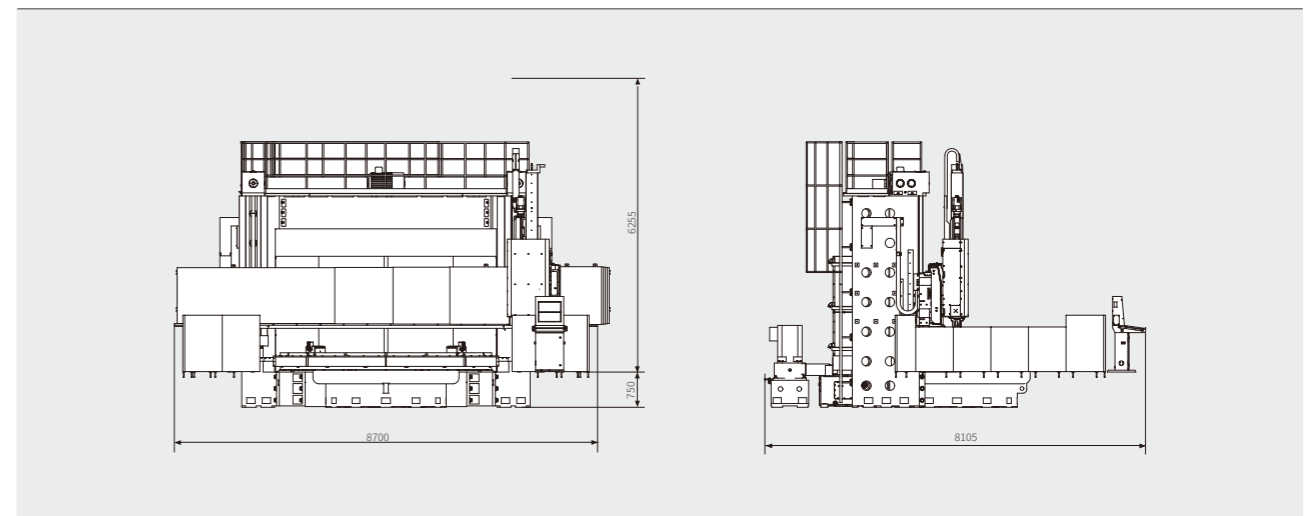

VNL500H/HK

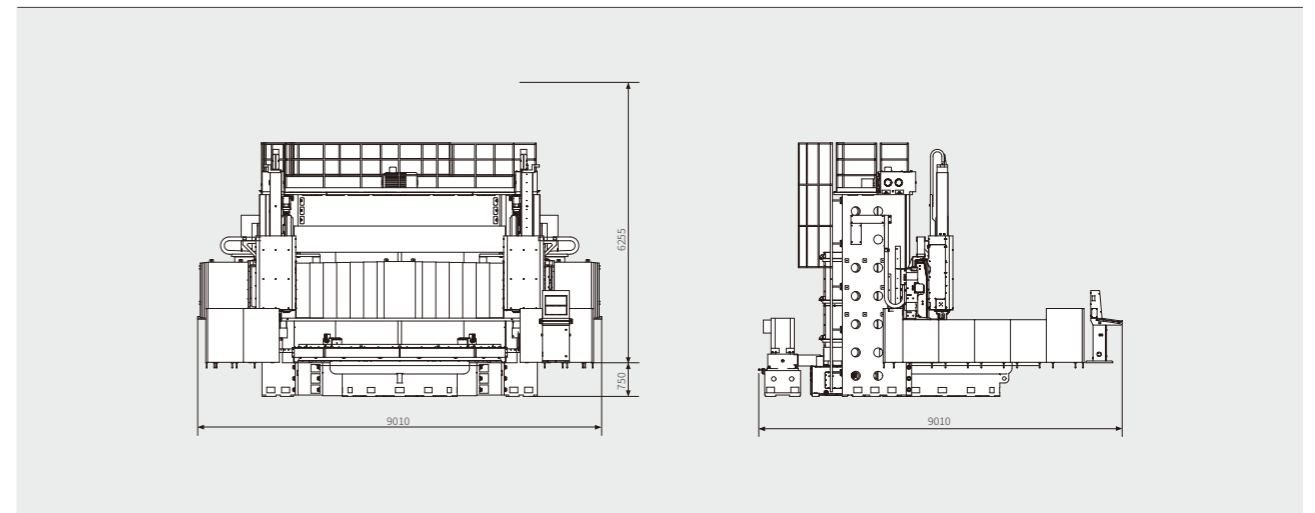

Item		Unit	VNL250S/D	VNL250SK/DK	VNL250SF/DF	VNL250SFK/DFK	VNL400S/D	VNL400SK/DK	VNL400SF/DF	VNL400SFK/DFK	VNL500S/H	VNL500SK/HK
Cutting capacity	Max. swing diameter	mm	Φ2750	Φ2750	Φ2750	Φ2750	Φ4000	Φ4000	Φ4000	Φ4000	Φ5000	Φ5000
	Max. cutting diameter	mm	Φ2500	Φ2500	Φ2500	Φ2500	Φ4000	Φ4000	Φ4000	Φ4000	Φ5000	Φ5000
	Max. workpiece height	mm	2000/2500	2000/2500	1000	1000	2000/2500/3150	2000/2500/3150	1000	1000	2000/2500/3150	2000/2500/3150
	Workpiece weight	kg	20000	20000	20000	20000	40000	40000	40000	40000	50000	50000
Travel	X/Z travel	mm	1820/1400	1420/1400	1820/1000	1420/1000	2265/1400	2175/1400	2265/1000	2175/1400	2765/1400	2675/1400
	X/Z rapid travel speed	m/min	9/9	9/9	9/9	9/9	6/6	6/6	6/6	6/6	6/6	6/6
	Main motor power	kW	55 (连续)	55 (连续)	55 (cont.)	55 (cont.)	75 (cont.)	75 (cont.)	75 (cont.)	75 (cont.)	75 (cont.)	75 (cont.)
	Worktable diameter	mm	Φ2250/Φ2500	Φ2250/Φ2500	Φ2250/Φ2500	Φ2250/Φ2500	Φ3600	Φ3600	Φ3600	Φ3600	Φ4500	Φ4500
Spindle	Max. worktable speed	r/min	160	160	160	160	80	80	80	80	50	50
	Max. worktable torque	N.m	40000	40000	40000	40000	125000	125000	125000	125000	160000	160000
Turret	Tool position	-	1	12(tool magazine)	1	12(tool magazine)	1	12(tool magazine)	1	12(tool magazine)	1	12(tool magazine)
	Turning tool shank size	mm	40×40	40×40	40×40	40×40	40×40	40×40	40×40	40×40	50×50	40×40
	Driven type	-	/	electric	/	electric	/	/	/	electric	/	/
	Servo motor torque	N.m	X38 / Z30	X38 / Z30	X38 / Z30	X38 / Z30	X38 / Z30	X38 / Z30	X38 / Z30	X38 / Z30	X38 / Z30	X38 / Z30
Machine accuracy	Positioning accuracy(X/Z)	mm	0.03/0.030	0.030/0.030	0.03/0.03	0.03/0.03	0.030/0.030	0.030/0.030	0.030/0.030	0.030/0.030	0.030/0.030	0.030/0.030
	Repeat positioning accuracy(X/Z)	mm	0.015/0.015	0.015/0.015	0.015/0.015	0.015/0.015	0.015/0.015	0.015/0.015	0.015/0.015	0.015/0.015	0.015/0.015	0.015/0.015
Others	CNC control system	-	NEWAY FANUC[SIEMENS]				NEWAY FANUC[SIEMENS]					
	Dimension (L×W×H)	mm	7080×4590×6850	7080×4590×6850	7080×4590×5500	7080×4590×5500	8700×5700×7200	8700×5700×7200	8700×5700×6100	8700×5700×5700	8870×5700×7200	8870×5700×7200
	Auco chip conveyor (Opt.)	-	sdie way	sdie way	sdie way	sdie way	sdie way	sdie way	sdie way	sdie way	sdie way	sdie way
	Machine weight	kg	42000/46000	43000/47000	32000/35000	33000/36000	66000/70000	67000/71000	51000/55000	52000/56000	76000/80000	77000/81000

Standard configuration:

Lubrication system, hydraulic unit, air gun, tri-color lamp, work light, standard tool holder.

Optional configuration:

Linear scale, tool setter, workpiece measurement probe, electric cabinet air conditioner, special tool holder, cooling system, water gun, oil-water separator, liquid level alarm, chip conveyor, chip cart, protection cover.

VNL Series- CNC Vertical Turning Center

- Mechatronics vertical design, compact and reasonable overall layout, easy to install and maintain;
- The base adopts a thermal symmetrical structure to overcome the influence of the temperature rise of the spindle on the machining accuracy;
- X/Z axis lead screw is pre-stretched structure, which can reduce the influence of temperature rise during machining on lead screw precision;
- The vertical structure avoids the roundness deviation caused by the gravity of the workpiece during horizontal clamping and ensures the roundness accuracy of the part;
- The weight of the workpiece ensures that the workpiece and the fixture are closely attached, so that the workpiece can obtain high positioning accuracy and machining accuracy;
- Suitable for valves, chemical, medical machinery and other industries, suitable for various complex shape parts processing, such as large, heavy and thin workpiece.



Spindle power torque diagram

(单位: mm)

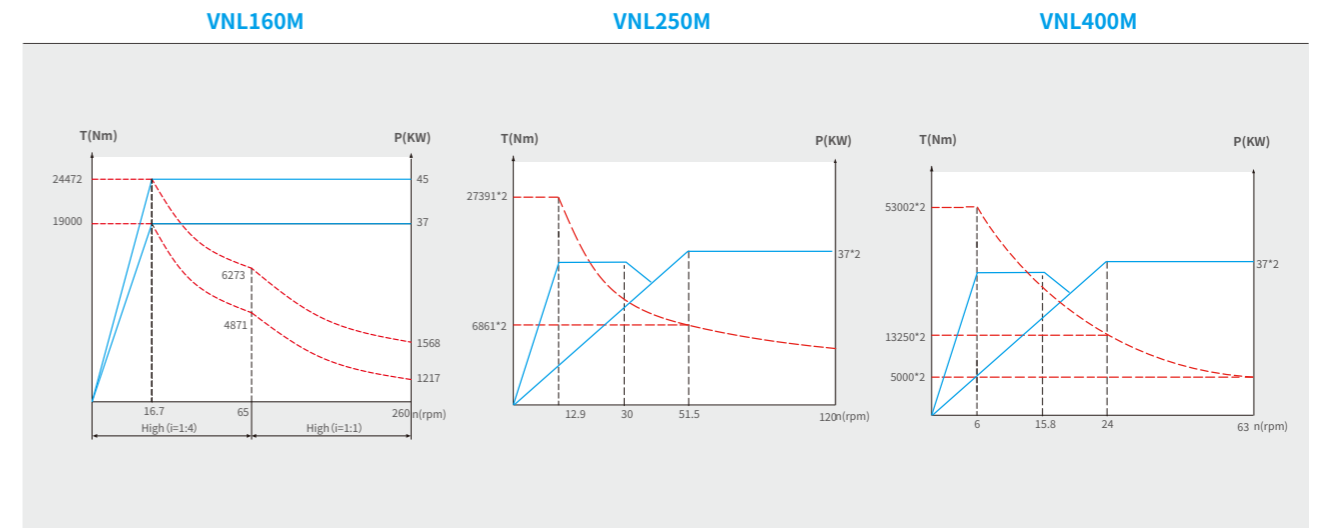
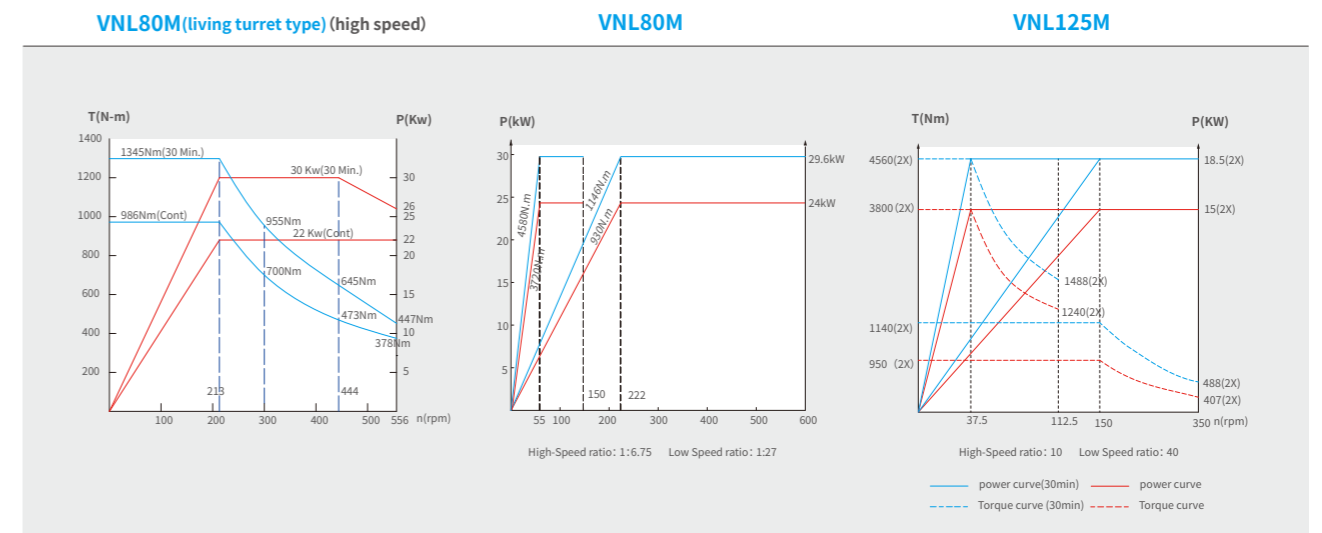
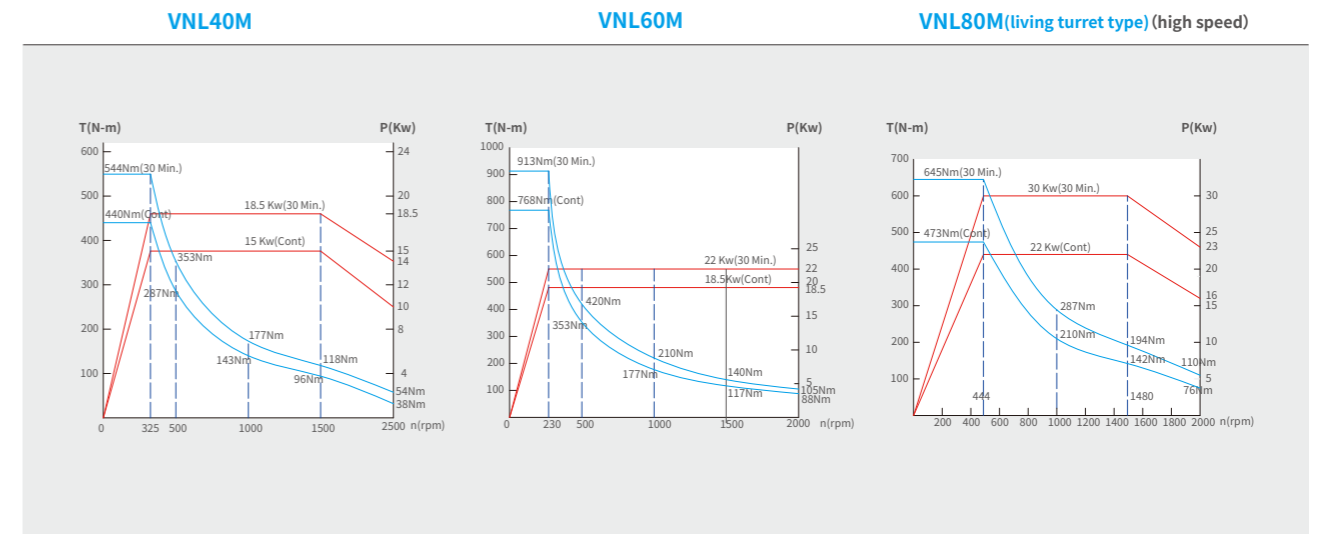

Tool interference diagram

(Unit: mm)

VNL40M/60M (BMT65)

VNL80M (BMT75)

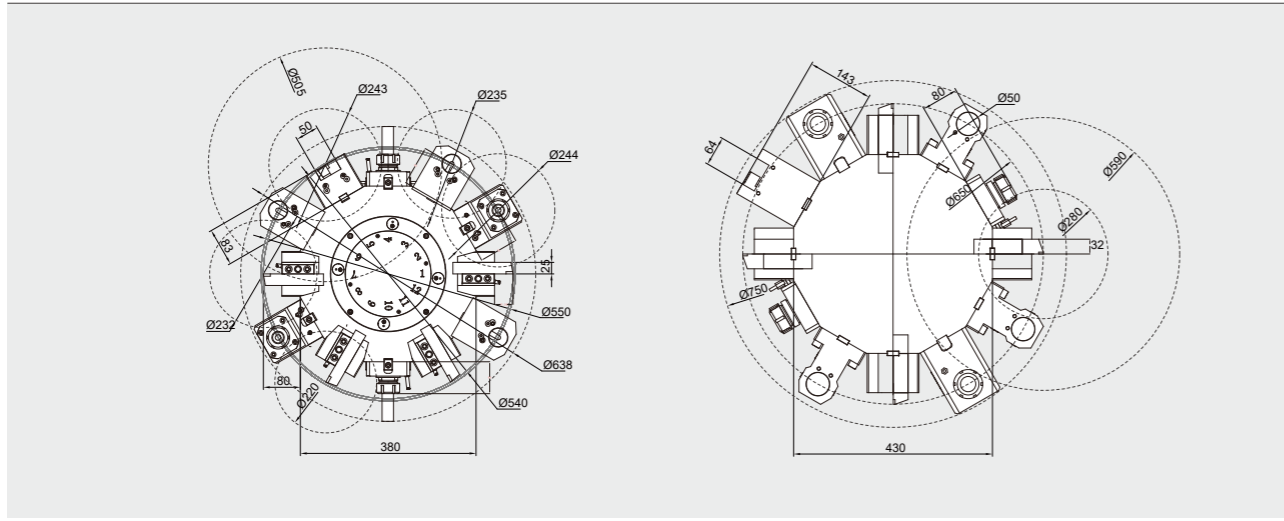

VNL80M

VNL160M

VNL125M

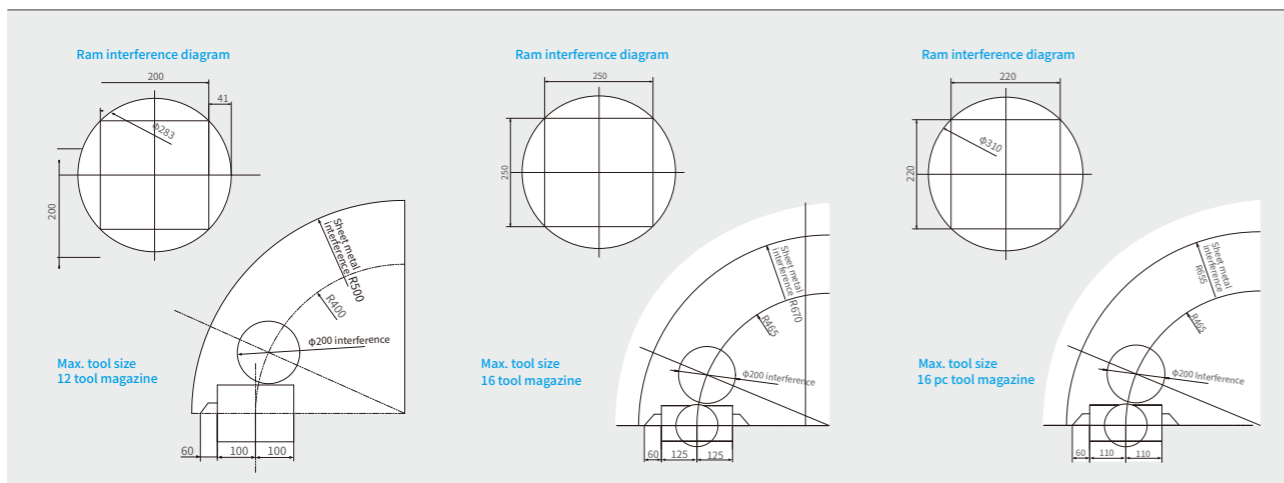

VNL250M

VNL400M

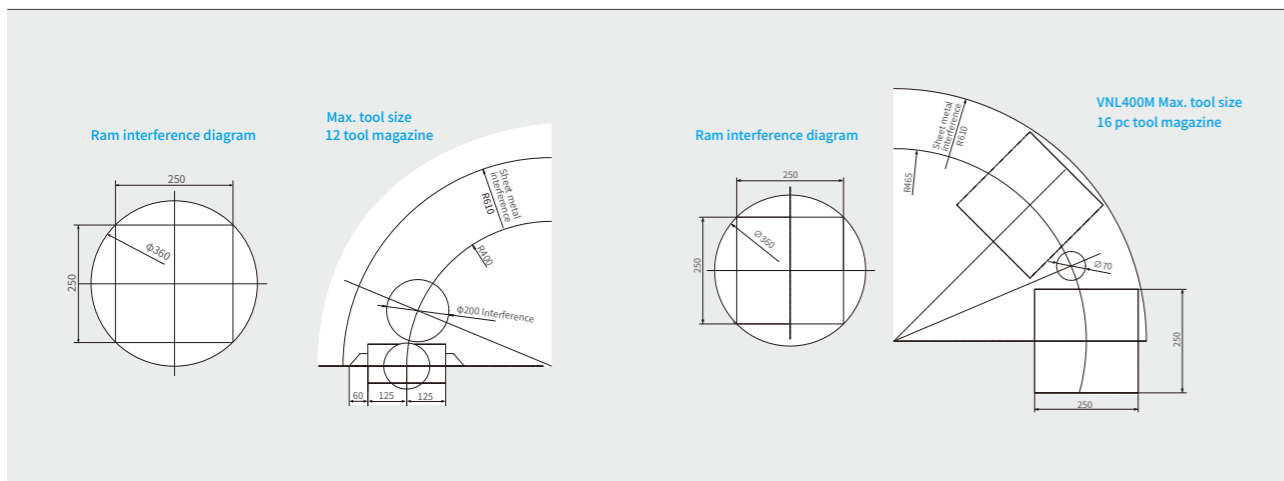

Machining area diagram

(Unit: mm)

VNL40/60M/80M

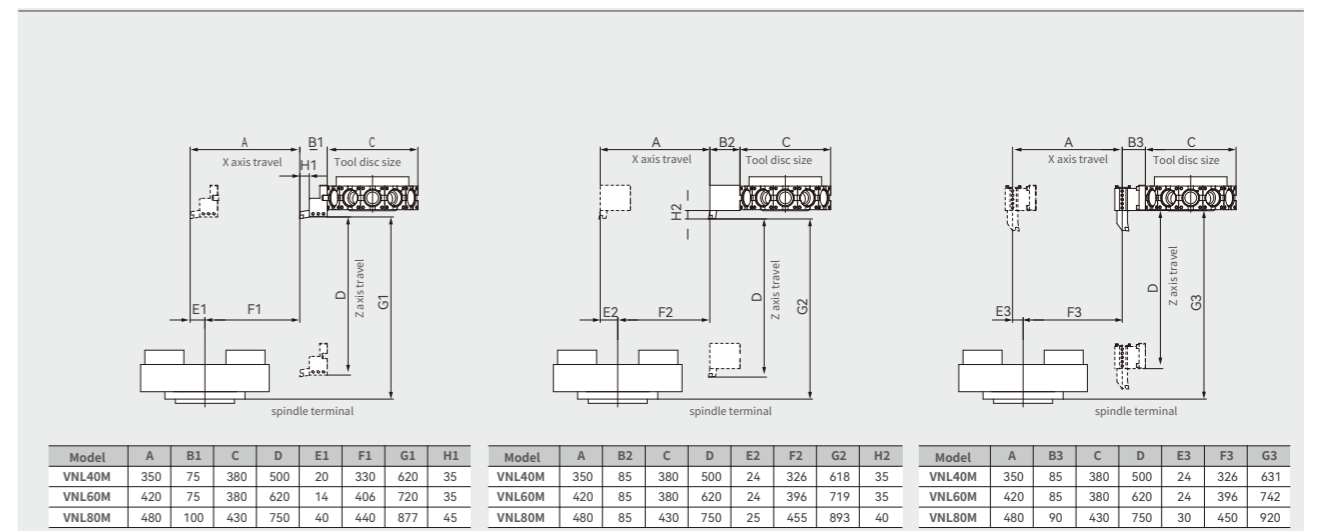

VNL40M

VNL60M

VNL80M

Model	A	B4	C	D	E4	F4	G4
VNL40M	350	69	380	500	14	336	708
VNL60M	420	69	380	620	14	406	819.5
VNL80M	480	82	430	750	22	458	990.5

Model	A	B5	C	D	E5	F5	G5
VNL40M	350	72	380	500	11	339	611
VNL60M	420	72	380	620	11	409	723
VNL80M	480	90	430	750	30	450	885

VNL80M

VNL125M

VNL160M

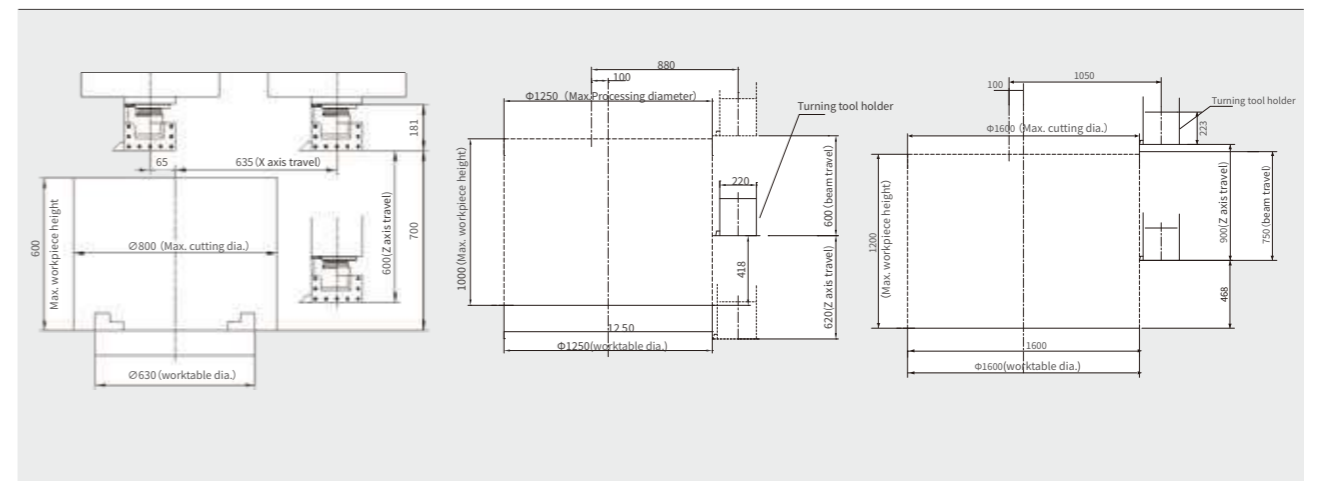

VNL250M

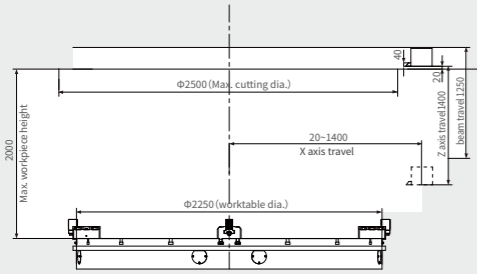

VNL400DM

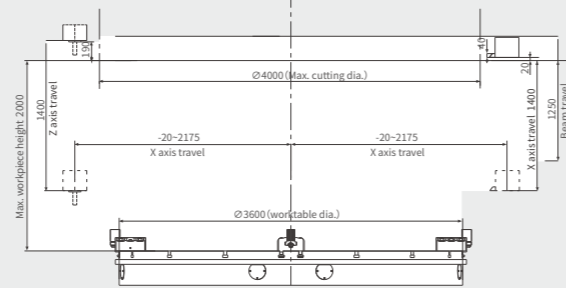

VNL160M

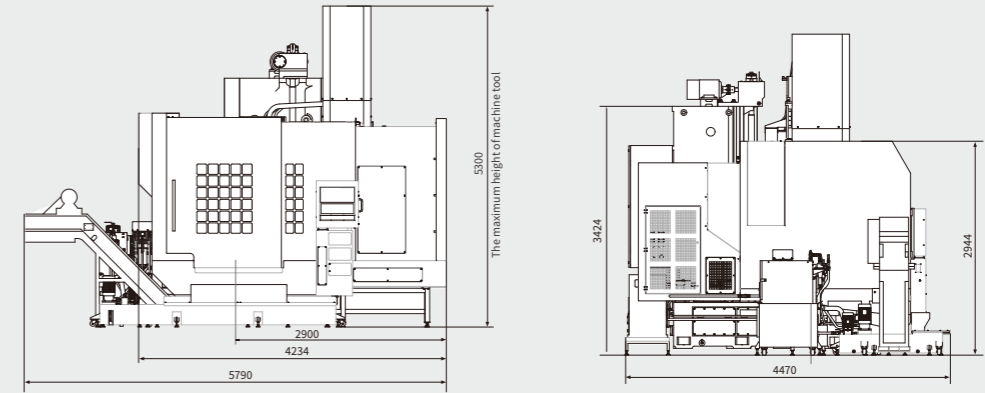

External dimensions

(Unit: mm)

VNL40M/60M

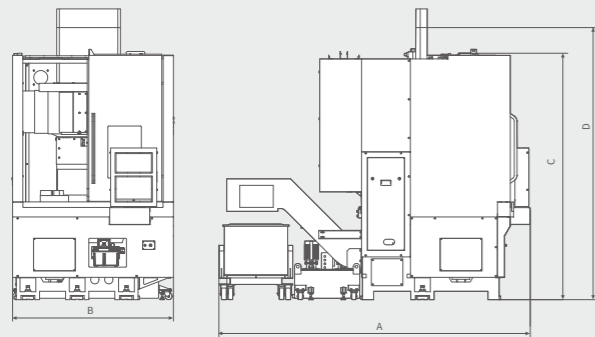

VNL80M

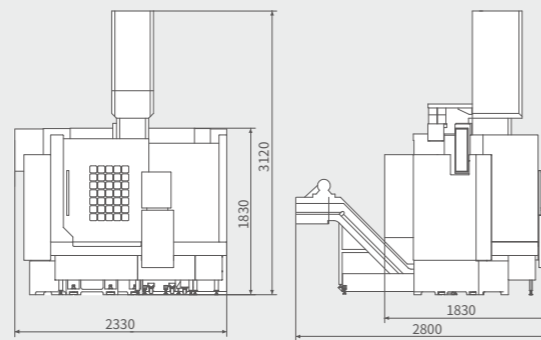

Model	A	B	C	D
VNL40M	3200	1730	2650	3100
VNL60M	3630	1870	2820	3500

VNL250M

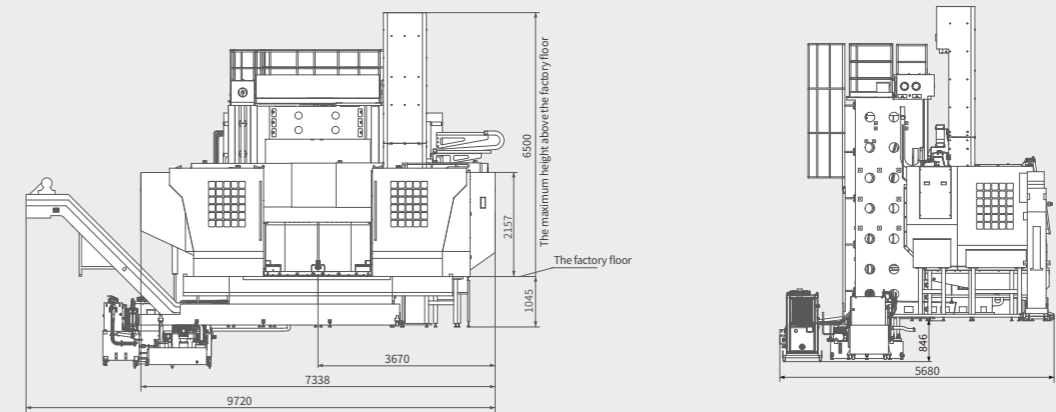

VNL80M(living turret type)

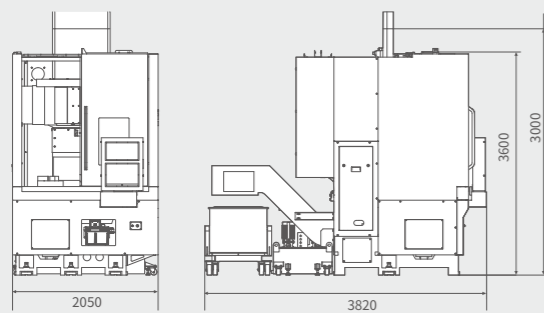

VNL125M

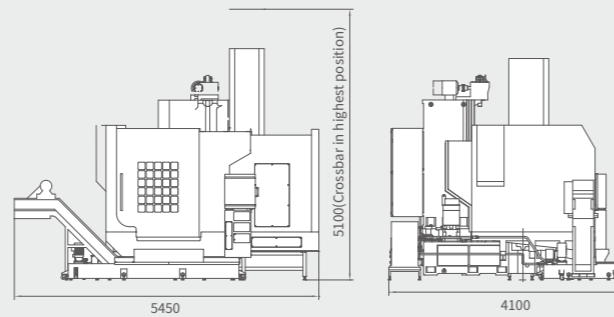

VNL400DM

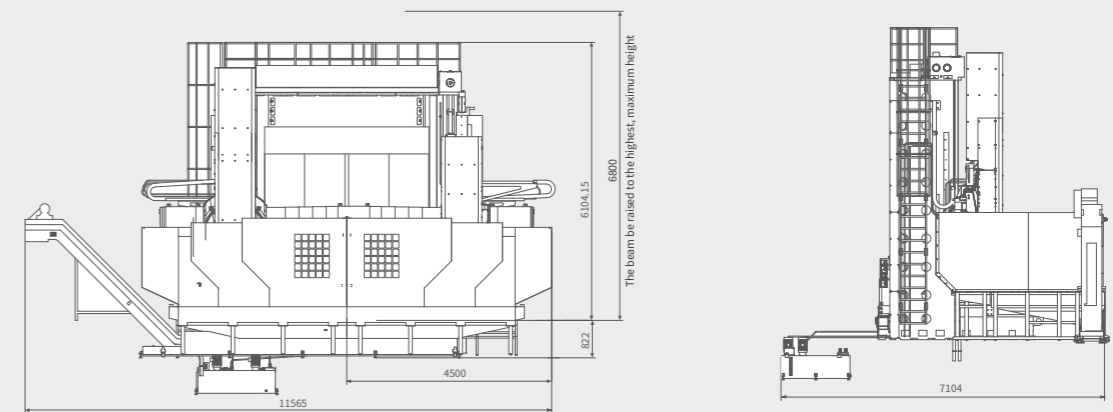

Item		Unit	VNL40M	VNL60M	VNL80M(living turret type)
Cutting capacity	Max. cutting dia.(shaft)	mm	Φ320	Φ550	Φ650
	Max. cutting dia.(disc)	mm	Φ600	Φ780	Φ850
	Max. swing diameter	mm	Φ620	Φ800	Φ900
	Max. workpiece height	mm	400	550	700
Travel	X/Z travel	mm	350/500	420/620	480/750
Spindle	Spindle nose	-	A2-8	A2-11	A2-11
	Spindle speed	r/min	50~2500	50~2000	50~2000
	Main motor power	kW	15/18.5	18.5/22	22/30
	Max. spindle torque	Nm	544	913	1345
Hydraulic chuck	Chuck diameter	inch	12	15	18
Speed	X/Z axis rapid travel speed	m/min	20/20	20/20	20/20
	Cutting feed rate	mm/min	1~2000	1~2000	1~2000
Turret	Tool position	-	12 (Horizontal)	12 (Horizontal)	12 (卧式)
	Living tool speed	r/min	4000	4000	4000
	Driven type	-	servo	servo	伺服
	Tool holder type	mm	BMT65	BMT65	BMT75
	Turning tool shank size	mm	25×25	25×25	32×32
	Boring tool holder diameter	mm	Φ40	Φ40	Φ50
Cutting capacity	Max. drilling capacity	-	Φ16×0.2	Φ16×0.2	Φ25×0.25
	Max. tapping capacity	-	M14×2/M20×1.5	M14×2/M20×1.5	M18×2.5/M27×2.0
	Max. groove milling capacity	-	Φ20×12×40	Φ20×12×40	Φ30×20×40
Machine accuracy	Positioning accuracy(X/Z)	mm	0.008/0.012	0.008/0.012	0.008/0.012
	Repeat positioning accuracy(X/Z)	mm	0.006/0.008	0.006/0.008	0.006/0.008
Others	CNC control system	mm	NEWAY FANUC[SIEMENS]		
	Power capacity	kVA	35	40	40
	Coolant tank capacity	L	240	340	340
	Dimension(L×W×H)	mm	1730×3260×3130	1900×3600×3400	2050×3840×3670
	Machin weight	Kg	6500	8000	9500

Standard configuration:

Hydraulic chuck, soft jaw, rear chip conveyor, chip cart, central lubrication system, hydraulic system, fully enclosed guard, air gun, work light, tri-color lamp, work light, tri-color lamp, electric cabinet heat exchanger.

Optional configuration:

Hard jaw, none-standard fixture, side chip conveyor, linear scale, auto-door, oil water separator, liquid level alarm, oil mist collector, two-stage pressure reducing valve, electronic door lock, electric cabinet air conditioner.

Item	Unit	VNL80M	VNL125M	VNL160M	VNL250M	VNL400DM	VNL500DM
Max. cutting dia.	mm	Φ800	Φ1250	Φ1600	Φ2750	Φ4000	Φ5000
Max. swing diameter	mm	Φ1000	Φ1500	Φ1800	Φ2500	Φ4000	Φ4000
Max. workpiece height	mm	600	1000	1200	2000/2500	2000/2500/3150	2000/2500/3150
Max. workpiece weight	kg	2000	5000	8000	20000	40000	50000
X travel	mm	-50~635	-100~780	-100~950	-20~1400	-20~2175	-20~2675
Z travel	mm	600	620	900	1400	1400	1400
Max. worktable dia.	mm	Φ630	Φ1250	Φ1600	Φ2250/Φ2500	Φ3600	Φ4500
Worktable speed	r/min	20~600	1~350	1~260	0.2~160	0.02~80	0.50~50
Max. C axis speed	r/min	5	2	5	2	2	2
Series of speed	Mechanical 2 steps	ZF dual-speed gearbox	stepless gearbox	ZF dual-speed gearbox	ZF dual-speed gearbox	ZF dual-speed gearbox	ZF dual-speed gearbox
Main motor power	kW	15*2	15*2	37/45	30*2	37*2	37*2
Spindle speed	r/min	1~2400		1~2400	1~2400	1~2400	1~2400
Spindle motor power	kW	7.5	7.5	7.5	11/15	22	22
Tool shank	-	BT50	BT50	BT50	BT50	BT50	BT50
Pull-stud	-	P50T-I(MAS403)	P50T-I(MAS403)	P50T-I(MAS403)	P50T-I(MAS403)	P50T-I(MAS403)	P50T-I(MAS403)
Ram section	mm	200×200	220×220	250×250	250×250	250×250	250×250
Max. spindle torque	N.m	4580	9000	19000	40000	100000	160000
Beam limit steps	step	/	5	6	5	/	/
Max. beam travel	mm	/	600	750	1250/1750	1250/1750/2400	1250/1750/2400
X/Z axis rapid travel speed	m/min	10/10	12/10	12/10	9/9	6/6	6/6
Feed speed	mm/min	1~2000	1~2000	1~2000	1~2000	1~1000	1~1000
Tool change type	-	automatic	automatic	automatic	automatic	automatic	automatic
Tool holder type	-	12	16	16	16	16	16
Turning tool shank size	mm	32×32	32×32	32×32	32×32	40×40	40×40
Max. tool size	mm	280W×150T×380L	280W×150T×380L	280W×150T×380L	280W×150T×380L	280W×150T×380L	280W×150T×380L
Max. tool weight	kg	35	50	50	50	50	50
Max. tool load	kg	360	640	640	640	640	640
Tool change time T-T	Sec	45	45	45	45	45	45
Positioning accuracy X	mm	0.025/1000	0.025/1000	0.025/1000	0.032/full travel	0.032/full travel	0.036/full travel
Positioning accuracy Z	mm	0.025/1000	0.025/1000	0.025/1000	0.032/full travel	0.032/full travel	0.032/full travel
Repeat positioning accuracy X	mm	0.010/1000	0.010/1000	0.010/1000	0.013/full travel	0.013/full travel	0.013/full travel
Repeat positioning accuracy Z	mm	0.010/1000	0.010/1000	0.010/1000	0.013/full travel	0.013/full travel	0.013/full travel
CNC control system		NEWAY FANUC[SIEMENS]					
Power capacity	kVA	65	75	85	120	140	140
Coolant tank capacity	L	300	500	600	600	1200	1200
Dimension(L×W×H)	mm	3350×4000×4500	5450×4100×5100	5790×4470×5300	9720×6500*6850	12000×9500×7000	13500×9700×7600
Machin weight	Kg	12000	21000	27000	47000	73000	87000

Standard configuration:

Coolant system and chip remove system, lubrication system, hydraulic system, external protection cover, air gun, tri-color lamp, work light, chip cart, standard tool holder.

Optional configuration:

Linear scale, tool setter, workpiece measurement probe, water gun, oil-water separator, liquid level alarm, electric cabinet air conditioner, special tool holder.

Industrial applications

Complete product specifications and rich selection of configurations ensure Neway vertical CNC lathe with wider machining application range for various industries.



Manufacturing & detection

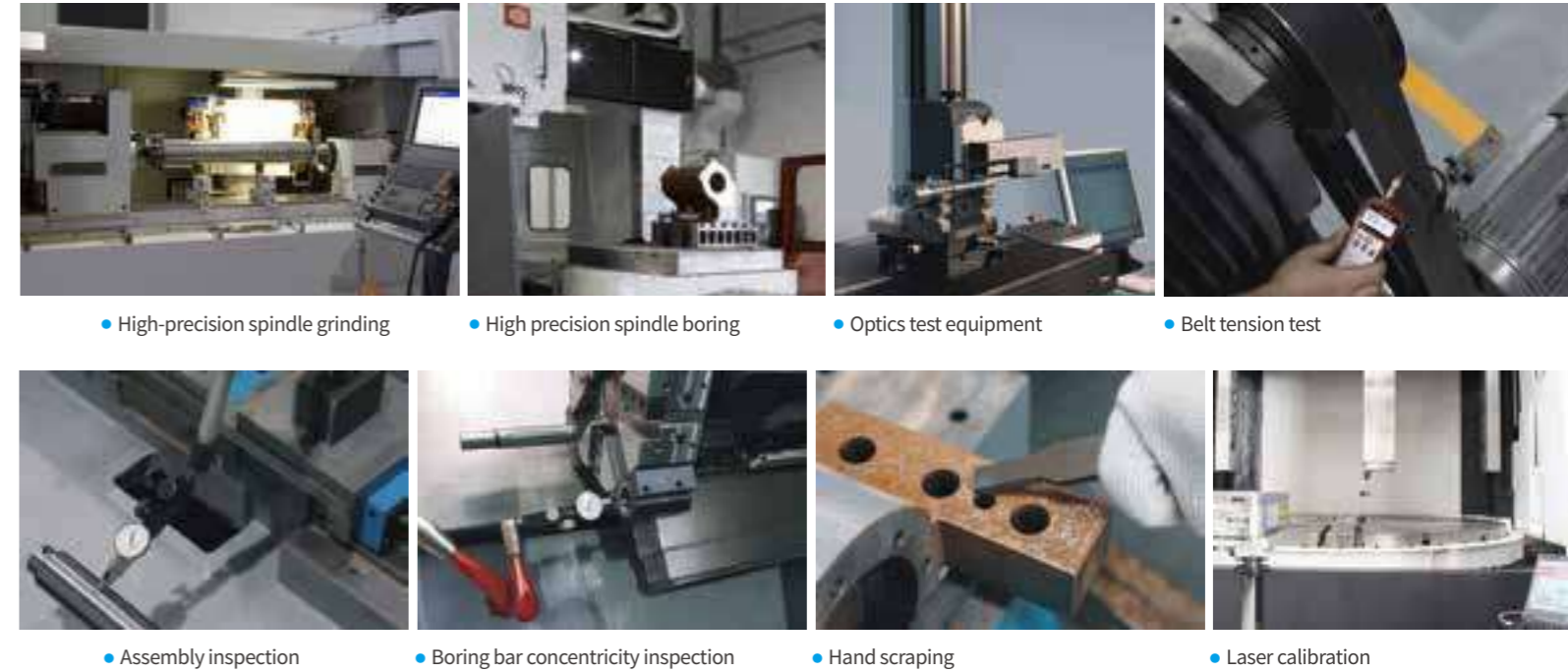

Control system

We used the PICTURE function to perform a second development of some human-machine friendly interfaces on the CNC.

Options

1 Machine tool configuration interface

Display the actual configurations of the machinetool, which can be used for debugging and maintenance



2 Cross-beam gear shift interface

Display the steps of cross-beam gear shifting and the conditions required for shifting.



3 M code interface

Introduce M code function of the machine tool



4 Automatic chip removal time setting interface

User set the chip conveyor running and stop time interval



5 Alarm information interface

Machine alarm information display and solution



6 Daily maintenance interface

Notes for daily maintenance and maintenance requirement setting



7 Turret, ATC maintenance interface

Tool position signal monitoring, maintenance operation instructions



- 01 Tool setter
- 02 Oil water separator
- 03 Water gun
- 04 Linear scale
- 05 Electric cabinet air conditioner
- 06 Oil mist collector
- 07 Workpiece measurement probe