

www.kinwa-lathe.com

SLANT BED CNC LATHE

斜床式CNC車床



CL-220 / CL-250 / CL-280 series

精度準確 品質卓越

SUPREME ACCURACY. EXCELLENT QUALITY.

KINWA
金和車床

金和精密股份有限公司
CHIN HUNG MACHINERY CO., LTD.

台中市大雅區田心街10號
No.10, Tianxin St., Daya Dist.,
Taichung City 428, Taiwan
Tel: +886-4-25663114 · 25666113
Fax: +886-4-25665254
E-mail: ufkinwa@ms15.hinet.net
www.kinwa-lathe.com



信賴的品牌 精準! 穩定!

A RELIABLE BRAND NAME
HIGH PRECISION! HIGH STABILITY!

SLANT BED CNC LATHE 斜床式CNC車床



配備工件收集器
Equipped with parts catcher



CL-220



CL-280

無配備工件收集器
Not equipped with parts catcher



V10 伺服刀塔

- 10刀位伺服刀塔。
- 伺服刀塔採用伺服馬達驅動，配合精密齒輪傳動，定位精準，換刀快速。

V10 SERVO TURRET

- 10-position servo turret.
- The servo turret is driven by a servo motor that is accompanied with high precision gear transmission and features high positioning accuracy and fast tool change.

高剛性機械結構

HIGHLY RIGID MACHINE STRUCTURE

■ 一體式結構

床身與底座為一體式結構設計，有效增加整體結構剛性。

■ 高級鑄鐵

床身與底座採用高級鑄鐵製成，並經應力消除。多年使用後，床身仍無變形之慮。

■ 主軸頭

高剛性主軸頭，具有最佳切削穩定性。

■ X, Z軸硬軌

X, Z軸為硬軌滑道。滑道面經硬化熱處理及精密研磨。耐重切削，穩定性高。

■ ONE-PIECE CONSTRUCTION

The bed and base are one-piece constructed that effectively boosts the rigidity of the entire structure.

■ HIGH QUALITY CAST IRON

The bed and base are manufactured from high quality cast iron and stress relieved for deformation-free performance year after year.

■ SPINDLE HEAD

The highly rigid spindle head features outstanding stability.

■ BOXWAY ON X, Z-AXIS

X, Z-axis are boxway. Slideways surfaces are hardened by heat treatment and precision ground, ensuring high stability in heavy cutting.



CL-220

CL-280

- 30°斜鞍式結構。剛性優異。
- 伺服刀塔。
- 油壓手動尾座 (CL-220 / CL-250)。
- 可程式副主軸式尾座 (CL-280)。
- 中空油壓三爪夾頭 (標配)。
- X, Z軸為硬軌滑道。耐重切削，加工穩定。
- 可分離式切削水箱。
- 發那科 (FANUC) Oi TF CNC控制器。

- 30° slant saddle structure with superior rigidity.
- Servo turret.
- Hydraulic manual tailstock (CL-220 / CL-250).
- Programmable sub-spindle type tailstock (CL-280).
- Hollow 3-jaw hydraulic chuck (standard accessory).
- Hardened slideways on X, Z-axis. Suitable for heavy cutting with high stability of machining.
- Separated coolant tank.
- FANUC Oi TF CNC controller.

- 夾頭: 8", 10"
- 旋徑: 590 mm
- 兩心間距: 580, 1180 mm
- 棒材容量: 52, 80 mm
- 主軸馬達: 25 HP

- Chuck: 8", 10"
- Swing: 590 mm
- Dist. between centers: 580, 1180 mm
- Bar capacity: 52, 80 mm
- Spindle motor: 25 HP

V12 動力刀塔 (選配)

- 義大利製12刀位動力刀塔。
- 亦選配BMT或VDI之動力刀塔 (台製)。
- 動力刀塔配合主軸之Cs軸功能，可執行銑削、鑽孔、攻牙加工作業。
- 動力刀塔之旋轉及定位採用伺服馬達驅動，換刀快速，定位精準。

V12 POWER TURRET (OPTIONAL)

- 12-position power turret. BARUFFALDI V12 live tool turret (VDI 30).
- Taiwan-made live tool turret BMT / VDI. (optional)
- The live tool turret in accompanied with the Cs-axis function of the spindle allows the machine to perform milling, drilling and tapping operations.
- The live tool turret rotation and indexing are driven by a servo motor for fast tool change and high positioning accuracy.

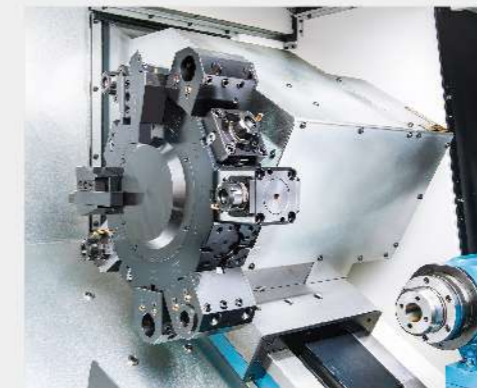



油壓手動尾座

- 尾軸心軸採用油壓驅動，使長工件拆裝快速、方便。
- 整體尾座移動為手動式。

HYDRAULIC MANUAL TAILSTOCK

- The tailstock quill movement is driven by hydraulic power, making long workpiece loading / unloading quick and convenient.
- The entire tailstock is moved manually.



中空油壓三爪夾頭

- 油壓三爪夾頭採用腳踏開關控制。
- 夾頭尺寸:
CL-220: Ø8", CL-250: Ø10"
CL-280: Ø10" / Ø12"

HOLLOW 3-JAW HYDRAULIC CHUCK

- The chuck clamping / unclamping is controlled by a foot pedal switch.
- Chuck size:
CL-220: Ø8", CL-250: Ø10"
CL-280: Ø10" / Ø12"

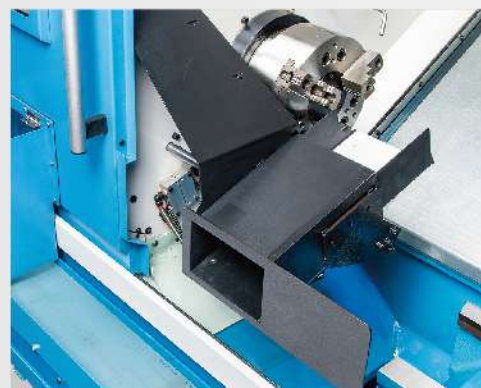

工件收集器 (選配)

- 自動收料，縮減工時與人力。
- 特殊設計的兩段式擋屑，可避免捲屑影響到工件收集。

PARTS CATCHER (OPTIONAL)

- Automatic parts catcher helps to shorten working time and manpower.
- The specially designed two-step chip stopper plate prevents curling chips from affecting parts collection.



手動刀具量測臂 (選配)

手動刀具量測臂具有感應器，可作精密之刀長量測，使刀具設定更方便。

MANUAL TOOL PRESETTER (OPTIONAL)

The manual tool presetter is equipped with a sensor, which is used for high precision measurement of tool length, making tool setting more convenient.

**伺服刀塔
SERVO TURRET**

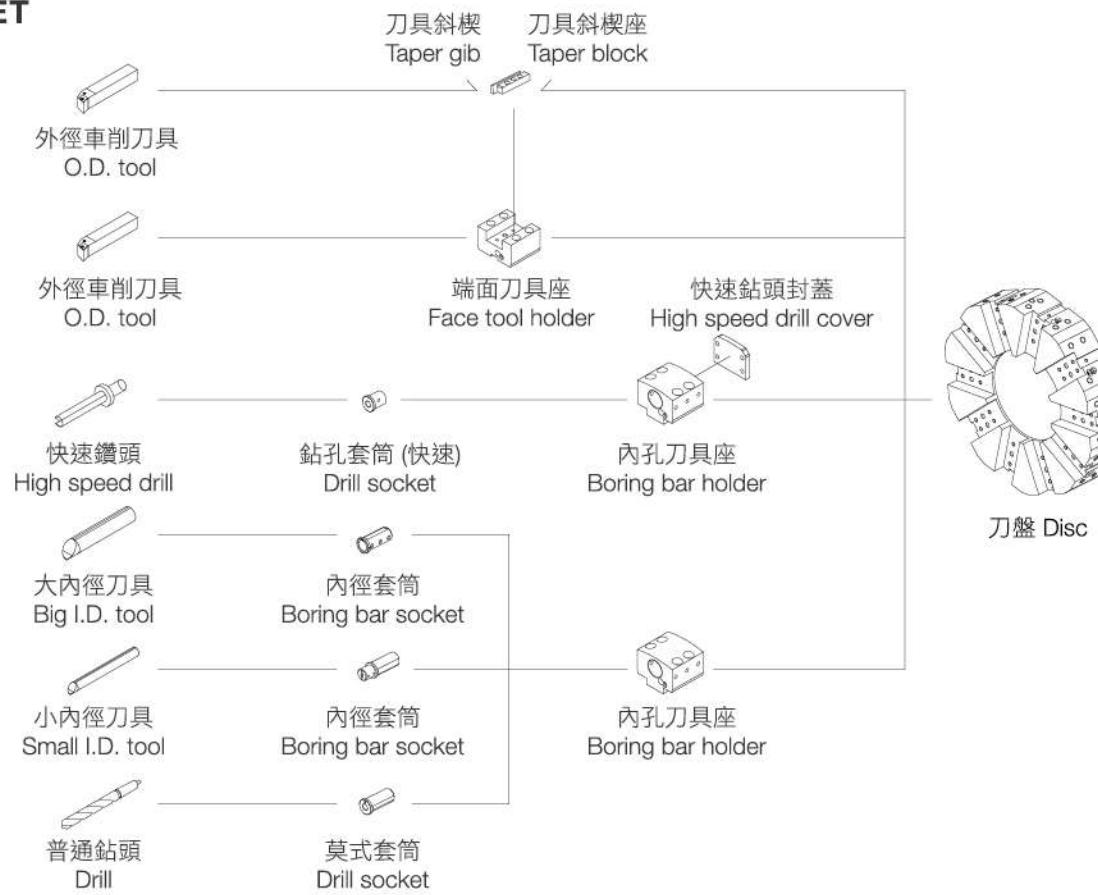

**VDI 動力刀塔
LIVE TOOL TURRET**

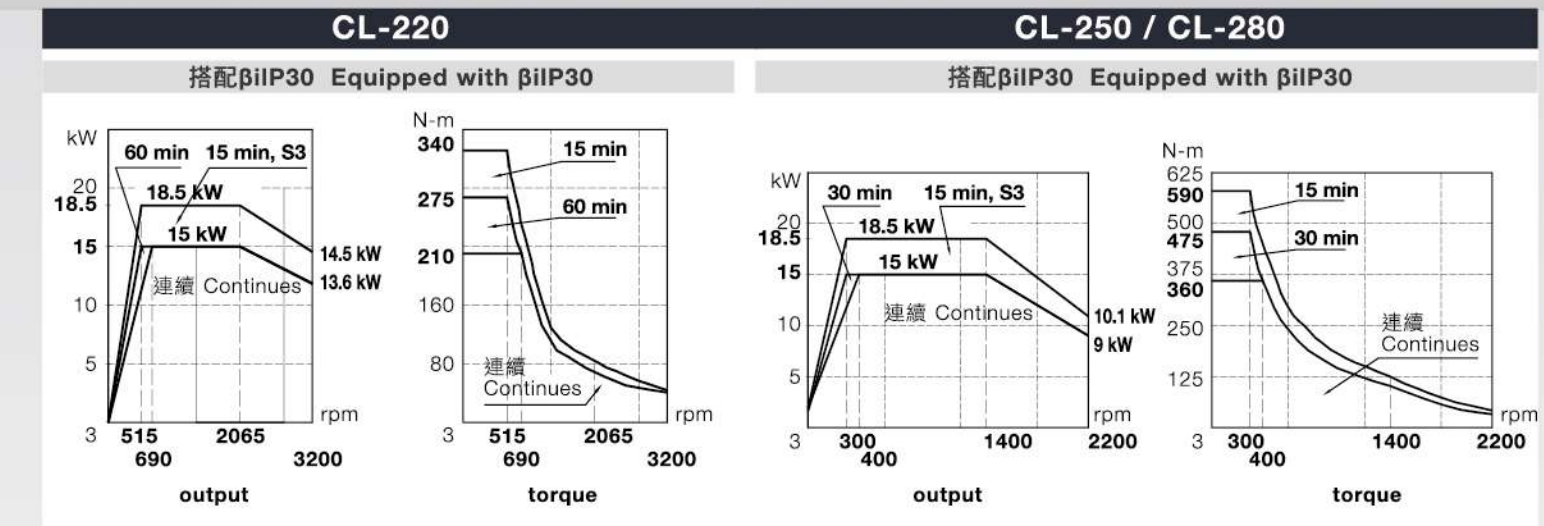
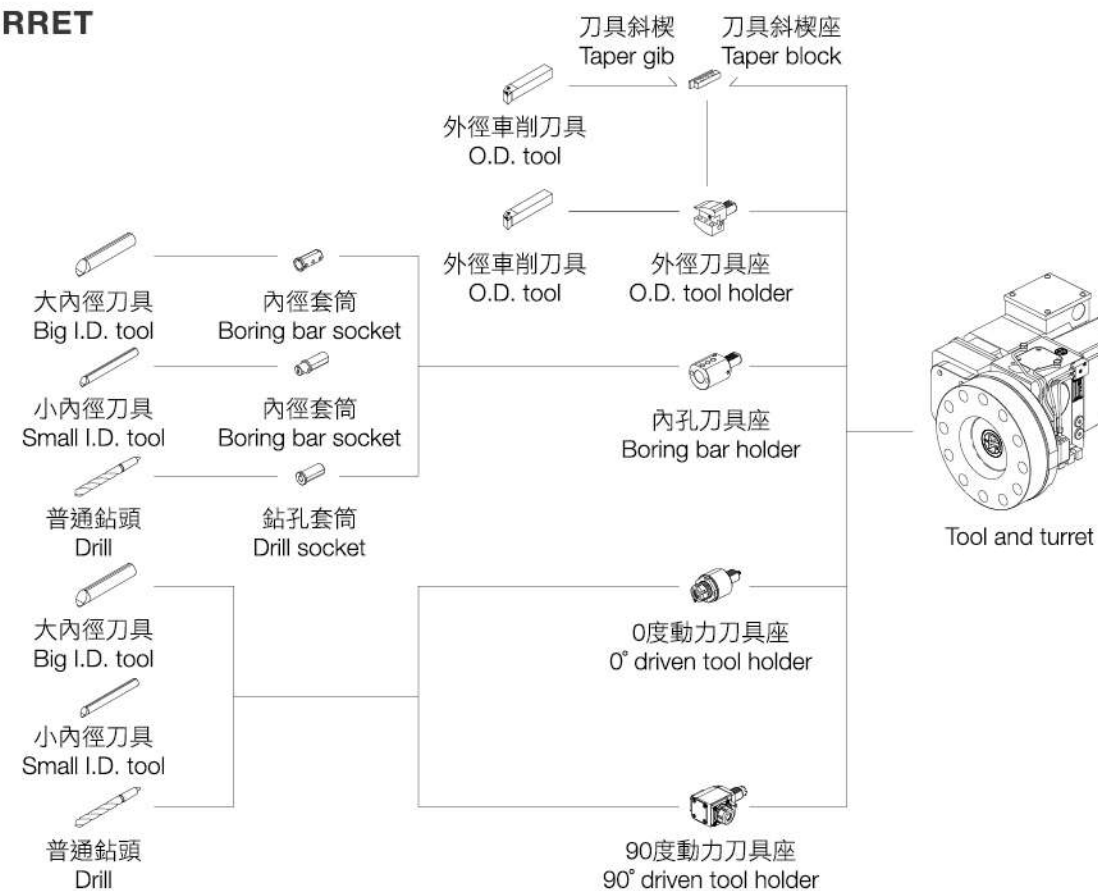

工作行程圖 WORKING TRAVEL DIAGRAM

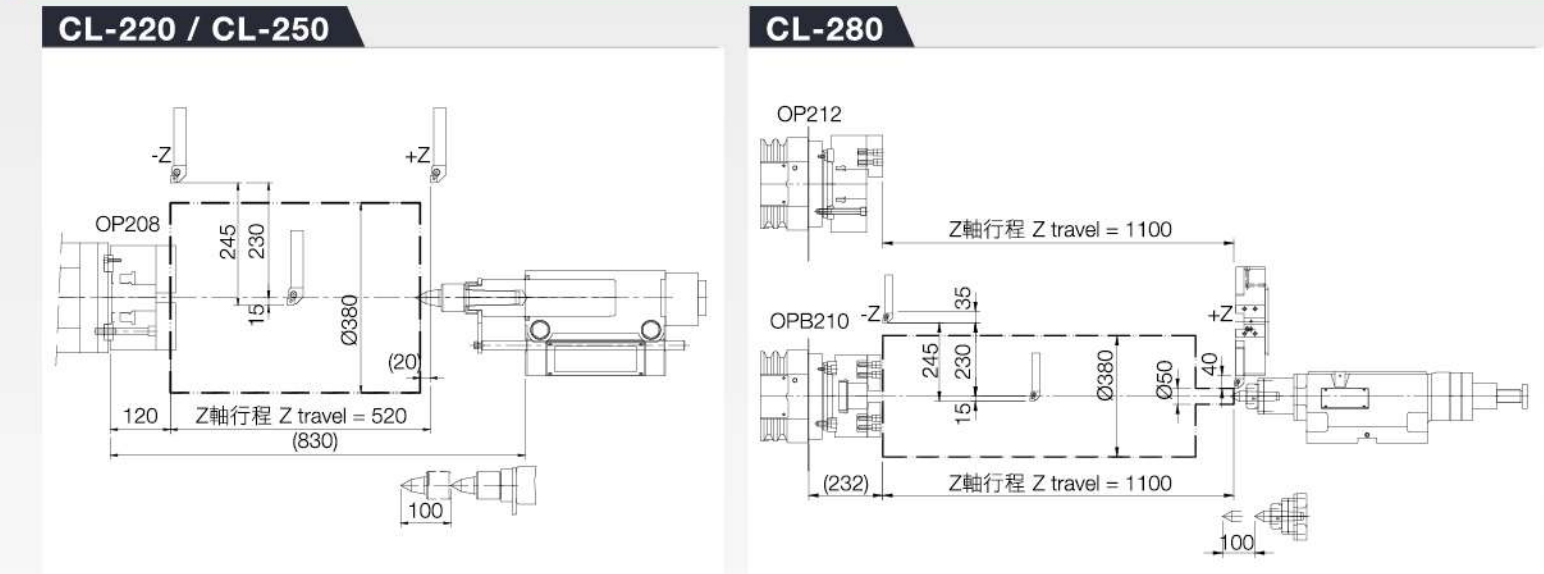

刀具干涉圖 TOOL INTERFERENCE

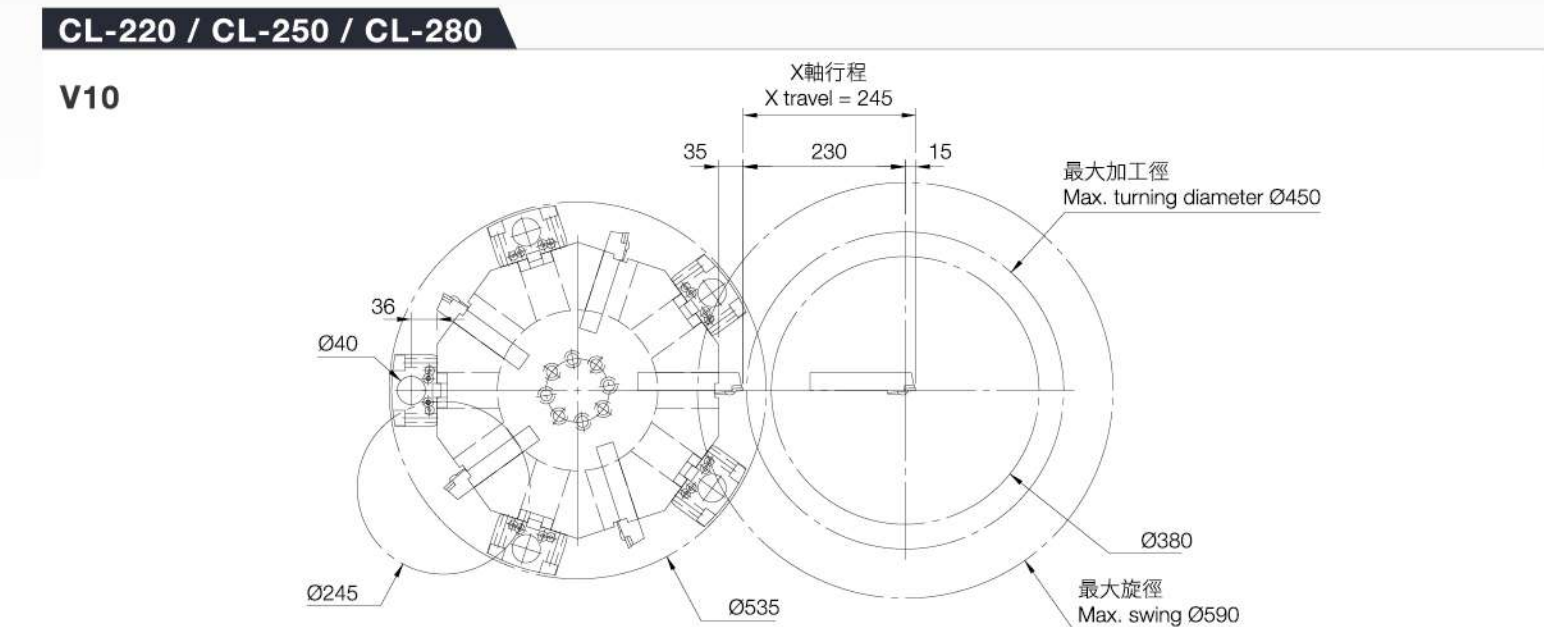

機械規格 MACHINE SPECIFICATIONS

項目	ITEM	CL-220	CL-250	CL-280
控制器	Controller	Oi-TF	Oi-TF	Oi-TF
最大旋徑	Max. swing	Ø590 mm	Ø590 mm	Ø590 mm
鞍面上旋徑	Swing over cross slide	Ø380 mm	Ø380 mm	Ø380 mm
最大加工直徑	Max. turning diameter	Ø450 mm (V10), Ø340 (VDI), Ø420mm (BMT)		
兩心間距	Distance between centers	580 mm	580 mm	1180 mm
X軸移動量	Travel of X axis	V8: 245 mm (230+15), VDI: 245 (175+70), BMT: 245 (210+235)		
Z軸移動量	Travel of Z axis	520 mm	520 mm	1100 mm
主軸轉速	Spindle speed	3200 r.p.m.	2200 r.p.m.	2200 r.p.m.
主軸鼻端	Spindle nose	A2-6	A2-8	A2-8
主軸孔徑	Spindle bore	Ø62 mm	Ø91 mm	Ø91 mm
夾頭(棒材容量)	Chuck (bar capacity)	8" (Ø52 mm)	10" (Ø80 mm)	10", 12" (Ø80 mm)
刀塔型式	Turret	V12 (VDI 30), V10伺服刀塔 Vertical 10-station servo turret, V12 (BMT 55)		
外徑切削工具	O.D. tool shank	□25 mm	□25 mm	□25 mm
內徑切削工具(最大)	I.D. tool shank (max.)	Ø40 mm	Ø40 mm	Ø40 mm
進給速度	Rapid traverse	X: 16 m/min, Z: 20 m/min		
尾座移動量	Stroke of tailstock	480 mm	480 mm	1000 mm
尾座心軸直徑	Diameter of tailstock quill	75 mm	75 mm	112 mm
尾座心軸斜度	Taper of tailstock quill	MT#4	MT#4	MT#4
尾座心軸移動量	Travel of tailstock quill	100 mm	100 mm	100 mm
主軸馬達	Spindle motor	25 HP (βilP30)		
伺服馬達	X軸	1.6 HP (βis8)*	2.4 HP (βis12)	2.4 HP (βis12)
	Z軸	2.4 HP (βis12)*	3.4 HP (βils22)	3.4 HP (βis22)
油壓馬達	Hydraulic motor	2 HP		
冷卻泵浦	Coolant pump	1HP		
機械高度	Height of machine	1950 mm	1950 mm	1930 mm
機械長度	Length of machine	3590 mm	3590 mm	4350 mm
機械寬度	Width of machine	1770 mm	1770 mm	1825 mm
機械重量	Weight of machine	3450 kg	3500 kg	5500 kg

• 以上規格如有變更恕不另行通知。 Specifications are subject to change without notice.
 • * * 選配 Option

標準配備及附件

- 油壓系統
- 中空油壓三爪夾頭
- 硬爪及軟爪各1組
- V10伺服刀塔
- 內孔刀具座5只
- 端面刀具座2只
- 內孔刀套 (M10, 12, 16, 20, 25, 32)各2只
- 莫氏套筒 (MT#2, #3)各1只
- 活動門及擋屑板
- 冷卻系統及高壓冷卻泵浦
- 冷卻水槽
- 鐵屑輸送機
- CL-220 / CL-250: 手動尾座及油壓心軸, 活動頂針MT#4
- CL-280: 可程式副主軸式尾座及油壓心軸, 固定頂針MT#4
- 工作燈
- 工具箱及調整工具

特別配備及附件

- 手動刀具量測臂
- 自動門
- 圓盤式油水分離機
- 變壓器
- 穩壓含變壓器
- CE規範
- 工件收集器
- 動力刀塔 (VDI / BMT)

機械外觀 MACHINE DIMENSIONS

CL-220 / CL-250

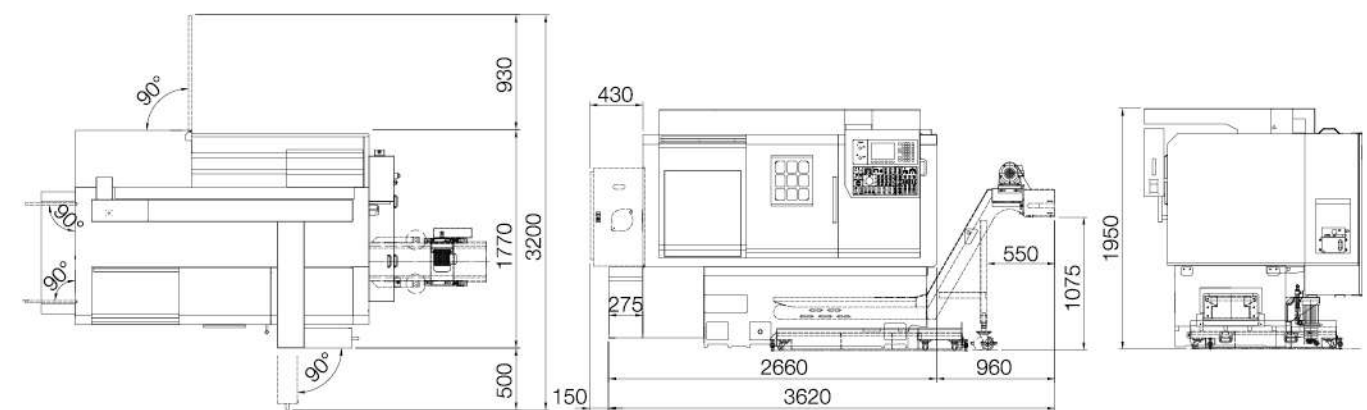

CL-280

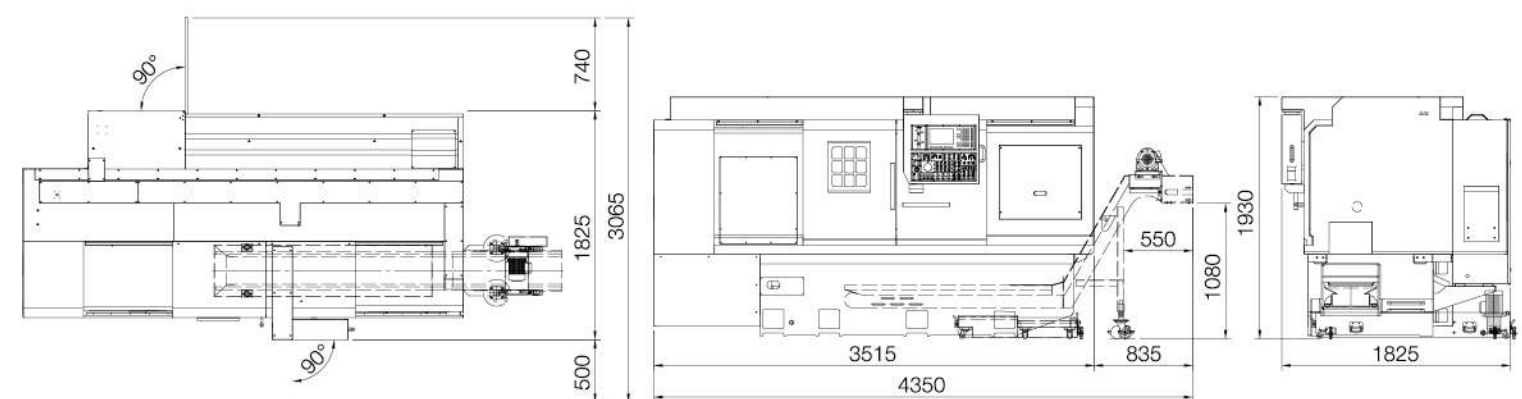

STANDARD EQUIPMENT & ACCESSORIES

- Hydraulic system
- 3-jaw hollow hydraulic chuck
- Hard jaw & soft jaw 1 set/each
- V10 servo turret
- Boring bar holder 5 pcs
- Facing tool holder 2 pcs
- Boring bar socket (M10, 12, 16, 20, 25, 32) 2 pcs/each
- Drill socket (MT#2, #3) 1 pc/each
- Moving door & Splash guard

OPTIONAL EQUIPMENT & ACCESSORIES

- Coolant system with high power
- Coolant tank
- Chip conveyor
- For CL-220 / CL-250: manual tailstock with hydraulic quill, living center MT#4
- For CL-280: programmable tailstock with built-in center and hydraulic quill, dead center MT#4
- Work light
- Tool box with adjusting tool
- Manual tool presetter
- Auto door
- Oil skimmer (disc-type)
- Transformer
- Voltage regulator with transformer
- CE approval specification
- Parts catcher
- Live tool turret (VDI / BMT)